

VU Research Portal

On the arrival theorem for communication networks

van Dijk, N.M.

1991

document version

Publisher's PDF, also known as Version of record

[Link to publication in VU Research Portal](#)

citation for published version (APA)

van Dijk, N. M. (1991). *On the arrival theorem for communication networks*. (Serie Research Memoranda; No. 1991-81). Faculty of Economics and Business Administration, Vrije Universiteit Amsterdam.

General rights

Copyright and moral rights for the publications made accessible in the public portal are retained by the authors and/or other copyright owners and it is a condition of accessing publications that users recognise and abide by the legal requirements associated with these rights.

- Users may download and print one copy of any publication from the public portal for the purpose of private study or research.
- You may not further distribute the material or use it for any profit-making activity or commercial gain
- You may freely distribute the URL identifying the publication in the public portal ?

Take down policy

If you believe that this document breaches copyright please contact us providing details, and we will remove access to the work immediately and investigate your claim.

E-mail address:

vuresearchportal.ub@vu.nl

91-81

ET

05348

Faculteit der Economische Wetenschappen en Econometrie

Serie Research Memoranda

On the Arrival Theorem for Communication Networks

Nico M. van Dijk

Research Memorandum 1991-81
December 1991



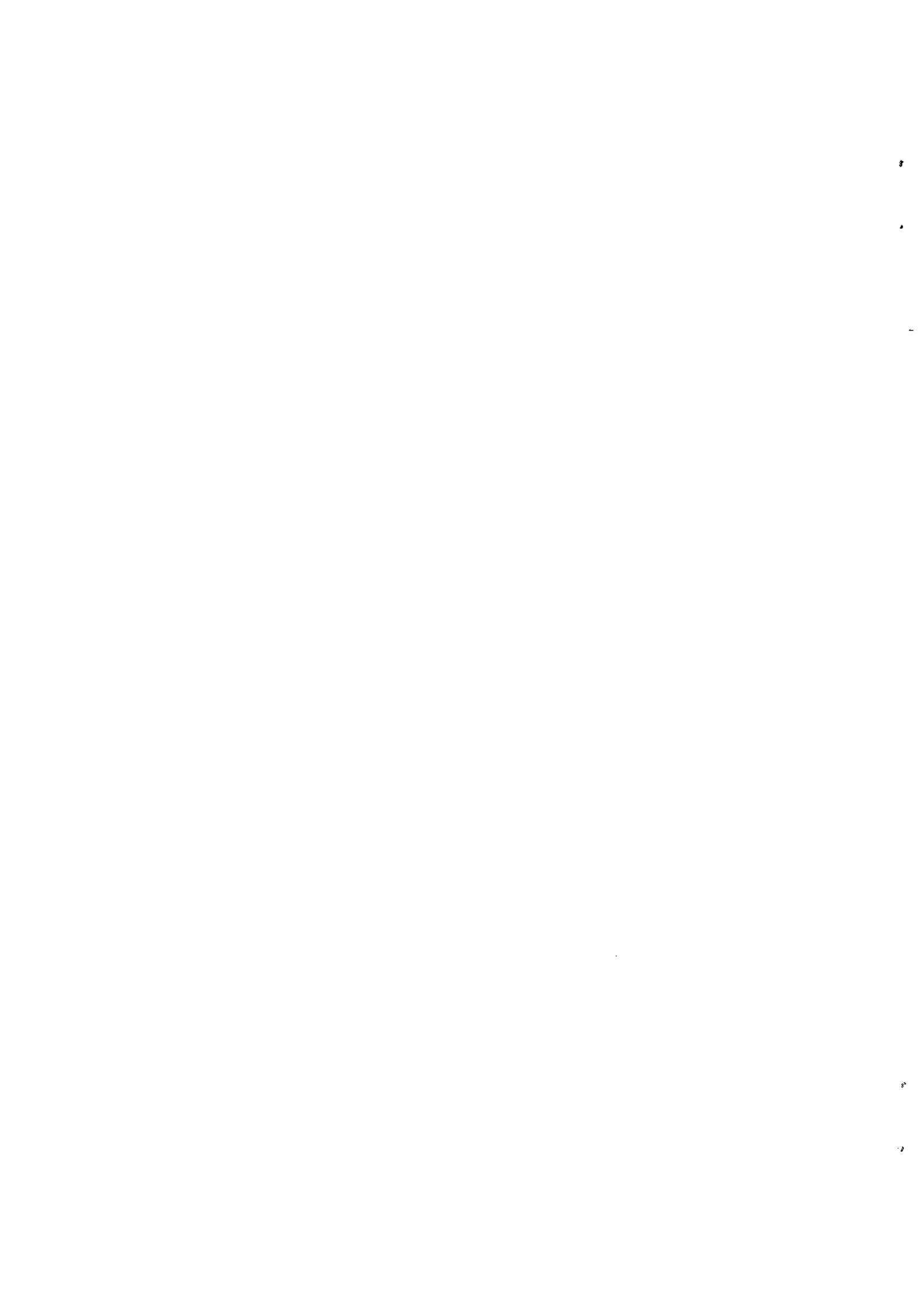

ON THE ARRIVAL THEOREM FOR COMMUNICATION NETWORKS

Nico M. van Dijk
Free University, The Netherlands

Abstract

The arrival theorem is investigated for communication networks that exhibit a product form. Two types of blocking protocols are distinguished:

- a delay protocol
- a retransmission protocol.

- (i) Under the delay protocol the arrival theorem is shown to fail.
- (ii) Under the more realistic retransmission protocol, however, the arrival theorem is shown to be generally valid provided the product form conditions are guaranteed.

The results show that the arrival theorem is no general consequence of product form expressions and extend the standard result for closed Jackson networks to communication networks with blocking. Examples include:

- Standard CSMA or BTMA protocols
- Circuit switch structures
- Rude-CSMA.

1 INTRODUCTION



Background

For over two decades queueing network modeling has become a most popular tool for performance evaluation of computer and communication networks. Unquestionably two major results that have motivated this direction are:

- Jackson's celebrated product form
- The MVA-algorithm.

This latter algorithm enables one to efficiently compute performance measure of interest such as throughputs and sojourn times for closed queueing networks (cf. [5],[6],[9],[12]). The algorithm is essentially based on the so-called:

- Arrival Theorem

The arrival theorem is a well-known result for closed Jackson queueing networks, that is networks with fixed routing probabilities and no blocking. Roughly speaking, the theorem states:

(1.1)

Upon arrival at a station a job observes the system as if in steady state at an arbitrary instant for the system without that job.

As Jackson networks have become famous for their product form expression while proofs of the arrival theorem for these networks have been given in the literature based on these product forms (cf. [9],[10],[13],[18]), the general impression seems to have grown that the arrival theorem is generally valid for any closed queueing or communication network that exhibits a product form. However, no formal support in this direction seems to be available.

Motivation

Particularly, over the last decade product form expressions have also been extended to communication networks or random access schemes such as CSMA, BTMA, Rude-CSMA and circuit switch structures (cf. [1], [2], [3], [4], [7], [11], [15]). In such networks, the transmission or broadcasting of different sources is dependent, for example due to limited resources or to avoid collisions, so that transmission requests may get blocked. To compute performance measures of interest such as the loss probability or throughput of these systems, an analog of the standard arrival theorem would be appealing. This would read as:

(1.2)

Upon transmission request by a source, this source observes the system as if in steady state at an arbitrary instant for the system without that source

Objective

This paper therefore aims to investigate this version of the arrival theorem for two types of blocking protocols:

- The delay or stop protocol (protocol 1)
- The retransmission protocol (protocol 2)

Results

- For the delay protocol the arrival theorem is shown to fail manner. In this case, it can apply only for special conditional probabilities.
- For the retransmission protocol, in contrast, the arrival theorem will apply under the conditions required to conclude the product form. Particularly, also randomized blocking such as in Rude-CSMA is allowed.

The result applies to a wide range of communication networks of which some illustration will be provided. This includes:

- CSMA and BTMA-structures
- Circuit switch architectures
- MAN-systems, and
- Rude-CSMA.

Outline

First, in section 2 we will give an instructive and somewhat counterintuitive example of the arrival theorem. Section 3 presents the general model and the condition for a product form result. The arrival theorem is then separately investigated for the delay and retransmission protocol in section 4.1 and 4.2. Section 5 contains some examples and an evaluation concludes the paper.

2 TWO INSTRUCTIVE EXAMPLES

Example 1

Consider a two-source communication network in which each source is alternatively in an idle (scheduling or non-transmitting) and busy (transmitting) mode. However, as there is only a single transmission channel, only one source can transmit and thus be busy at a time. When a source requests to start a transmission while the other source is already busy, this request is blocked and lost and the source has to remain idle to schedule a new request (retransmission).

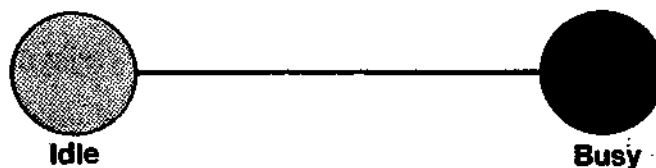

Assume that the time to schedule a next request is exponential with parameter γ_h for some source $h=1,2$ and that the duration of a transmission is also exponential with parameter μ_h for source $h=1,2$.

Let the state (s_1, s_2) denote by s_h the status of source h where $s_h=0$ means idle and $s_h=1$ means busy, $h=1,2$. The steady state distribution at the set of

possible states

$$C = \{(0,0), (1,0), (0,1)\}$$

is then determined by the global balance equations:

$$(2.1) \quad \begin{array}{l} \text{(i)} \quad \pi(1,0) \mu_1 = \pi(0,0) \gamma_1 \\ \text{(ii)} \quad \pi(0,1) \mu_2 = \pi(0,0) \gamma_2 \\ \text{(iii)} \quad \pi(0,0) [\gamma_1 + \gamma_2] = \pi(1,0) \mu_1 + \pi(0,1) \mu_2 \end{array}$$

where we note that (i) and (ii) can be interpreted as "balance per source". These also imply (iii) and yield the "product form solution":

$$(2.2) \quad \pi(s_1, s_2) = c \left(\frac{\gamma_1}{\mu_1} \right)^{s_1} \left(\frac{\gamma_2}{\mu_2} \right)^{s_2} \quad (s_1, s_2) \in C$$

Here one may note that expression (2.2) factorizes to the individual sources as if they were independent and in isolation with mean idle time γ_h^{-1} and mean busy time μ_h^{-1} for source h , up to the fact that the state (1,1) is not possible, as reflected by the normalization constant c . This justifies the phrase: "product form".

Arrival theorem example

Now let us investigate the arrival theorem as formulated by (1.2). That is, let us determine the probability distribution of the status of source 2 when source 1 requests to start a transmission. We denote this distribution by $\pi^1(s_2)$. Then:

$$(2.3) \quad \begin{array}{l} \pi^1(0) = \frac{\pi(0,0)\gamma_1}{\pi(0,0)\gamma_1 + \pi(0,1)\gamma_1} = \frac{\mu_2}{\mu_2 + \gamma_2} \\ \pi^1(1) = \frac{\pi(0,1)\gamma_1}{\pi(0,0)\gamma_1 + \pi(0,1)\gamma_1} = \frac{\gamma_2}{\mu_2 + \gamma_2} \end{array}$$

which corresponds exactly with the probability distribution of source 2 when it was in isolation following an alternating renewal process with means $1/\gamma_1$ and $1/\mu_2$ for being in idle or busy mode. For example, with $\gamma_1 = \gamma_2 = \mu_1 = \mu_2 = 1$ we have:

$$(2.4) \quad \boxed{\pi^1(0) = \pi^1(1) = \frac{1}{2}}$$

As source 2 in isolation represents the system without source 1, in this case we can thus state:

$$(2.5) \quad \boxed{\text{The arrival theorem applies}}$$

Example 2

Now let us reconsider a modification in which, roughly speaking, the strict dependence between the two sources is reduced to 50% as follows. Both sources are allowed to transmit at the same time, but in contrast a source is discouraged to schedule a transmission by a factor $\frac{1}{2}$ when the other source is already transmitting. More precisely, the scheduling rate of source 1 is given by:

$$(2.6) \quad \begin{cases} \gamma_1 & \text{when } s_2 = 0 \\ \frac{1}{2} \gamma_1 & \text{when } s_2 = 1 \end{cases}$$

and similarly for source 2 depending on s_1 .

Product form

The set of possible states is now given by:

$$C = \{(0,0), (1,0), (0,1), (1,1)\}$$

and the global balance equations become:

$$\begin{aligned}
 \pi(0,0) [\gamma_1 + \gamma_2] &= \pi(1,0) \mu_1 + \pi(0,1) \mu_2 \\
 \pi(1,0) [\mu_1 + \frac{1}{2} \gamma_2] &= \pi(0,0) \gamma_1 + \pi(1,1) \mu_2 \\
 \pi(0,1) [\frac{1}{2} \gamma_1 + \mu_2] &= \pi(0,0) \gamma_2 + \pi(1,1) \mu_1 \\
 \pi(1,1) [\mu_1 + \mu_2] &= \pi(0,1) \frac{1}{2} \gamma_1 + \pi(1,0) \frac{1}{2} \gamma_2
 \end{aligned}
 \tag{2.7}$$

which are also verified by balance equations per source:

$\pi(0,0) \gamma_1 = \pi(1,0) \mu_1 \quad \text{(balance per source 1)}$
$\pi(0,1) \frac{1}{2} \gamma_1 = \pi(1,1) \mu_1 \quad \text{(balance per source 1)}$
$\pi(0,0) \gamma_2 = \pi(0,1) \mu_2 \quad \text{(balance per source 2)}$
$\pi(1,0) \frac{1}{2} \gamma_2 = \pi(1,1) \mu_2 \quad \text{(balance per source 2)}$

with the "product form" solution:

$$\pi(s_1, s_2) = \begin{cases} c \left(\frac{\gamma_1}{\mu_1} \right)^{s_1} \left(\frac{\gamma_2}{\mu_2} \right)^{s_2} & (s_1, s_2) \neq (1,1) \\ c \left(\frac{\gamma_1}{\mu_1} \right) \left(\frac{\gamma_2}{\mu_2} \right) \frac{1}{2} & (s_1, s_2) = (1,1) \end{cases}
 \tag{2.9}$$

Here, the term "product form" must be interpreted in somewhat wider sense as also a scaling factor has been included. Roughly speaking, it could still be called a product form as the parameters μ_1 and μ_2 are involved by factors $(1/\mu_1)$ and $(1/\mu_2)$ when the source is busy. Essentially, the balance per source will be responsible for this product form feature as will be analyzed more detailed in section 3.

Arrival theorem counterexample

Let us reinvestigate the arrival distribution as per (1.2) seen by source 1 upon transmission request where we directly assume $\gamma_1 = \gamma_2 = \mu_1 = \mu_2 = 1$. Then:

$$\pi^1(0) = \frac{\pi(0,0)1}{\pi(0,0)1 + \pi(0,1)\frac{1}{2}} = \frac{2}{3} \neq \frac{1}{2}$$
$$\pi^2(1) = \frac{\pi(0,1)}{\pi(0,0)1 + \pi(0,1)\frac{1}{2}} = \frac{1}{3} \neq \frac{1}{2}$$

As the arrival theorem (1.2) would have required (2.4), in this case, and despite the fact that the source dependence seems to be reduced, we have to conclude:

The arrival theorem
fails

3 GENERAL MODEL

Consider a communication network of M sources, numbered $1, \dots, M$ where each source is either in an idle (scheduling or non-transmitting) or busy (transmitting) mode depending on the actual protocol in order as described below.

In either case, let $H = \{h_1, h_2, \dots, h_n\}$ denote the set of busy sources. And assume that source h has

an exponential scheduling rate γ_h
an exponential transmission rate μ_h

Further, we introduce a blocking/delay function: $A(h|H)$,
we write:

$$H + h = H \cup \{h\}$$

$$H - h = H \setminus \{h\}$$

and we denote the set of possible states by C .

Retransmission protocol (P_1)

Source H always schedules a next transmission request after an exponential period with parameter γ_h . When the system is in state H and source $h \in H$ requests to start a transmission, this request is accepted with probability $A(h|H)$ and blocked with probability $1-A(h|H)$. When blocked, the request is lost and the source has to schedule a new request.

Delay protocol (P_2)

When the system is in state H, the scheduling rate for a next transmission request by source h is delayed by a factor $A(h|H)$ and given by $\gamma_h A(h|H)$. Particularly, when $A(h|H)=0$, the scheduling is stopped. A transmission request, however, is always accepted.

One might question why this protocol distinction is made as they seem effectively equivalent. Indeed, as will be clear from the global balance equations (3.3) below, in the exponential case the steady state distributions are the same. This itself is already amazing from a physical point of view.

Viz., a scheduling of a next transmission may have been delayed or interrupted during some period of its scheduling under the P_2 -protocol, while upon the actual epoch of the request $A(h|H)=1$ so that no blocking would have been experienced at all under the P_1 -protocol. Indeed, in the non-exponential case this equivalence will no longer be generally valid. As shown in [15] it remains valid only under the additional product form condition below. More importantly in the line of the present paper, the protocol distinction will be essential when dealing with the arrival theorem.

Invariance condition

There exists a function $P(\cdot)$ at C such that for all H, $H+h \in C$:

(3.1)

$$P(H+h) = P(H) A(h|H)$$

or equivalently, such that for any $H=(h_1, h_2, \dots, h_n) \in C$ and any permutation $(i_1, i_2, \dots, i_n) \in (1, 2, \dots, n)$:

(3.2)

$$P(H) = \prod_{k=1}^n A(h_k | h_1, \dots, h_{k-1})$$

Remark

The equivalence of the conditions (3.1) and (3.2) is directly related to Kolmogorov's invariance criterion for reversibility, see [8], p.21, and can be proven similarly to p.22 of this reference. We will briefly discuss the verification and provide some examples later on.

Proposition 3.1

Under the invariance condition (3.1), with c a normalizing constant and with π_1 and π_2 the steady state distribution under protocol P_1 and P_2 respectively, we have

(3.3)

$$\pi_1(H) = \pi_2(H) = P(H) \left[\prod_{h \in H} \frac{\gamma_h}{\mu_h} \right]$$

Proof

We need to verify the global balance equations for both protocols. These are given by:

$$\pi(H) \sum_{h \in H} \mu_h + \pi(H) \sum_{h \in H} \gamma_h A(h|H)$$

=

(3.4)

$$\sum_{h \in H} \pi(H-h) \gamma_h A(|H-h) + \sum_{h \in H} \pi(H+h) \mu_h$$

where for the retransmission protocol we have deleted blocked transitions as they would provide exactly the same contribution to both the left and right hand side and where we must substitute $\pi(H)=0$ for $H \in C$. These global balance equations in turn would be satisfied by verifying the more detailed balance equations per source:

(3.5)

$$\pi(H) \mu_h = \pi(H-h) \gamma_h A(h|H-h) \quad (H \in C)$$

However, this source balance relation is immediately checked by substituting (3.1) and (3.4). The proof is hereby completed. \square

Discussion of invariance condition

The invariance condition may at first glance seem impractical for verification. However, in many concrete examples the actual complexity will be significantly reduced by exploiting the underlying structure. As such examples have been extensively studied in the literature (cf. [2], [3], [15], [17]) we only present some examples in section 5 for the purpose of illustration and would like to mention here one special case which covers a wide range of examples.

Special case 3.1 (Coordinate convex)

Assume that C , the set of admissible states, is such that

$$(3.7) \quad \boxed{H \in C \Rightarrow H-h \in C \quad \text{for all } h \in H, H \in C}$$

while

$$(3.8) \quad A(h|H) = \begin{cases} 1 & H+h \in C \\ 0 & \text{otherwise} \end{cases}$$

The product in (3.2) is then equal to 1 regardless of the order in which sources become busy so that:

$$(3.9) \quad \boxed{P(H) = 1 \quad (H \in C)}$$

Some examples are given in section 5.

4 THE ARRIVAL THEOREM

Let us now investigate the arrival theorem as formulated by (1.2). More precisely, we wish to evaluate the steady state distribution of the state H of the other sources that a source, say α , observes when it completes a scheduling period and requests to start a transmission. We denote this distribution by:

$$\Pi_M^\alpha(H)$$

and also introduce the notation:

$$\Pi_M(H) \text{ and } \Pi_{M-\alpha}(H)$$

as given by (3.3) as $\pi(\cdot) = \pi_1(\cdot) = \pi_2(\cdot)$ for the system with sources $1, \dots, M$ and for the same system with source α excluded.

4.1 Delay protocol

Recall the special coordinate convex case 3.1 and consider a state $H \in C$ and source $\alpha \in H$ such that $H + \alpha \notin C$. Hence, by virtue of (3.8):

$$A(\alpha|H) = 0$$

Under the delay protocol the scheduling of source α is thus interrupted in state H so that a transmission request by source h can never take place when the other sources are in state H . Thus, necessarily:

while

$$\begin{array}{l} \Pi_M^\alpha(H) = 0 \\ \Pi_{M-\alpha}(H) > 0 \end{array}$$

We thus have to conclude as before that:

(4.1)

The arrival theorem fails.

Remark

With randomized delay factors $A(\alpha|H)$, as illustrated by example 2 of section 2, essentially the same inconsistency remains present, but kept more hidden, so that the arrival theorem also fails in such cases. Statement (4.1) can thus be regarded as generally true under the delay protocol.

4.2 Retransmission protocol

First note that by substituting

$$(4.2) \quad c = \bar{c} (\gamma_1 \dots \gamma_M)^{-1}$$

we can rewrite expression (3.3) for $\pi(H) = \pi_M(H)$ as:

$$(4.3) \quad \pi_M(H) = \bar{c} P(H) \prod_{h \in H} \mu_h^{-1} \prod_{h \notin H} \gamma_h^{-1}$$

Under the retransmission protocol, the arrival distribution upon transmission request by source α is given by:

$$(4.4) \quad \pi_M^\alpha(H) = \frac{\pi_M(H) \gamma_\alpha}{\sum_{H'} \pi_M(H') \gamma_\alpha} = \frac{\bar{c} P(H) \prod_{h \in H} \mu_h^{-1} \prod_{h \in H, h \neq \alpha} \gamma_h^{-1}}{\sum_{H'} \bar{c} P(H') \prod_{h \in H'} \mu_h^{-1} \prod_{h \in H', h \neq \alpha} \gamma_h^{-1}}$$

However, in the latter expression the common normalization factor \bar{c} cancels in the denominator and numerator, and the remaining summation in the denominator represents the normalization constant as according to (4.3) for the system with sources $1, \dots, M$ but source α excluded, that is without source α . As also the numerator is of the product form (4.3), we have thus proven the arrival theorem result:

$$(4.5) \quad \boxed{\pi_M^\alpha(H) = \pi_{M-\{\alpha\}}(H)}$$

4.3 Conditional arrival theorem

As a more detailed version of the arrival theorem one can also investigate the arrival distribution upon transmission request by a source α , given that the system state is contained in some set or has some property.

Let us give one special case for which a conditional arrival theorem also applies for the delay protocol. Consider a specific source α and some subset S^α such that

$$(4.6) \quad \boxed{A(\alpha|H) = 1 \quad \text{for all } H \in S^\alpha}$$

and consider the conditional arrival distribution for source α at S^α ,

denoted by $\pi_M^\alpha(H|S^\alpha)$. Then, under both the delay and retransmission protocol and by recalling the rewritten form (4.3), we obtain as in (4.4):

$$(4.7) \quad \pi_M^\alpha(H|S^\alpha) =$$

$$\pi_M(H) \gamma_\alpha / \left[\sum_{H' \in S^\alpha} \pi_M(H') \gamma_\alpha \right] =$$

$$P(H) \prod_{h \in H} \mu_h^{-1} \prod_{h \in H, h \neq \alpha} \gamma_h / \left[\sum_{H' \in S^\alpha} P(H) \prod_{h \in H} \mu_h^{-1} \prod_{h \in H, h \neq \alpha} \gamma_h \right]$$

But by virtue of (4.3) again, the latter expression coincides exactly with the conditional steady state probability of state H at S^α for the system without source α . Hence:

(4.8)

Under both the delay and retransmission protocol and with S^α satisfying (4.6), a conditional arrival theorem applies as:

$$\pi_M^\alpha(H|S^\alpha) = \pi_{M-\alpha}(H|S^\alpha)$$

Remark

This result may at first instance seem trivial as source α cannot experience blocking at S^α . However, one should realize that the possible blocking outside S^α or the blocking experienced at S^α by other sources also indirectly influences the steady state probabilities and thus also the conditional steady state probabilities at S^α so that (4.8) is not trivial. For instance, in the CSMA example 5.1 below, (4.6) and thus (4.8) hold for:

$$S^5 = \{H \mid 1,3,6 \notin H\}$$

while the distribution at S^5 would be different if, for example, the link between 1 and 5 would be cancelled.

5 EXAMPLES

An extensive number of applications that satisfy the conditions (3.1), (3.2) or (3.7) and (3.8) can be found in [2], [3], [15], and [17]. In this section we merely aim to provide some examples to illustrate the potential of the general framework while keeping the paper self-contained.

For each of these, as well as any other that can be adopted from these references, the investigation of the arrival theorem, its validity under the retransmission protocol and its failure under the delay protocol, appear to be new.

5.1 CSMA and BTMA protocol (cf. [1],[2],[3],[7],[11],[14])

(i) CSMA

Sources corresponding to transmitters can be graphically represented such that adjacent sources (neighbors) cannot be busy (transmit) at the same time.

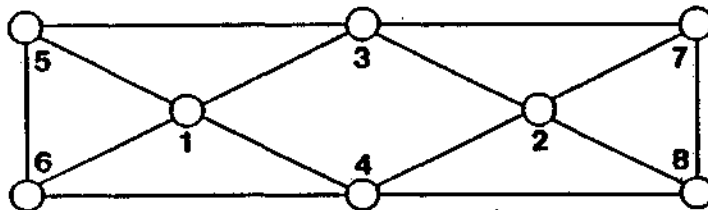

In practice this is achieved by the so-called Carrier-Sense Multiple Access (CSMA) protocol in which a transmitter senses the state of its channel before it will start a transmission. If one of these channels is sensed busy the transmission is aborted (inhibited). For example, in the figure above, source 1 prohibits sources 3-6 to start a transmission. With $N(h)$ the set of neighbors of source h , the coordinate convexity condition is guaranteed by:

$$(5.1) \quad C = \left\{ H \mid h_2 \notin N(h_1) \text{ for all } h_1, h_2 \in H \right\}$$

(ii) BTMA

In the figure above, sources 1 and 2 can transmit at the same time as they are outside hearing range. This may lead to a collision and losses at nodes 3 and 4. To eliminate this so-called Hidden Terminal Problem, under the Busy Tone Multiple Access scheme, introduced in [14], a source which senses a busy channel from a transmitting neighbor will broadcast a busy tone signal to all its neighbors to prevent any other neighbor to start a transmission. The coordinate convex set C given by (5.1) now still applies if we let $N(h)$ represent all one- and two-step neighbors from h .

5.2 Circuit switch networks (cf. [4])

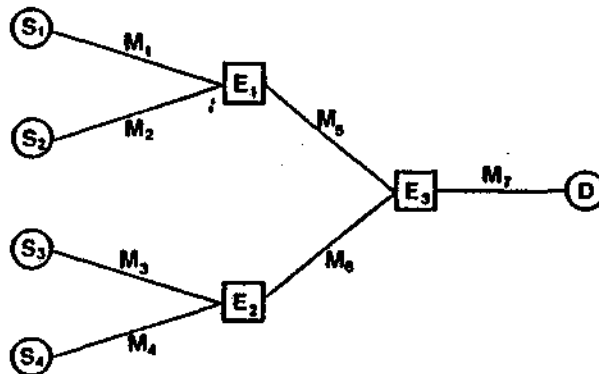

Consider the circuit switch network below with 4 types of sources and M_j trunks (links) at trunkgroup $j=1, \dots, 7$. A transmission by a source of type i requires a free trunk from each of the trunkgroups from S_i to D at the same time. With n_i the number of busy sources of type i , the coordinate convexity condition (3.7) is now guaranteed by C the set of all states H with:

$$n_i \leq M_j \quad (i=1, \dots, 4)$$

$$n_1 + n_2 \leq M_5$$

$$n_3 + n_4 \leq M_6$$

$$n_1 + n_2 + n_3 + n_4 \leq M_7$$

5.3 Rude-CSMA (cf. [11])

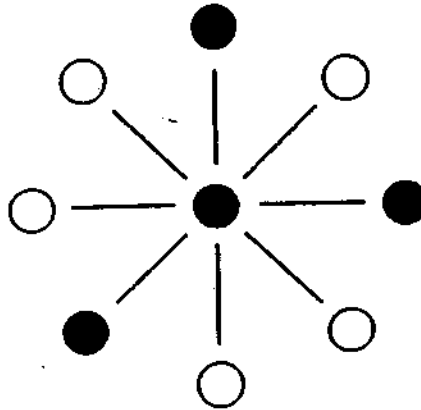

The following extension of the standard CSMA-model was proposed in [11] under the name of Rude-CSMA. Roughly speaking, it aims to take into the account the environment without precise information which neighbors are busy and which not. A transmission request by source h while the other sources are in state H is accepted with probability

$$A(h|H) = x \frac{N_0^h(H)}{N_0^h(H) + N_1^h(H)}$$

where $N_0^h(H)$ and $N_1^h(H)$ are the numbers of idle and busy neighbors of source h in state H , and where x and y are fixed given system values. For example, $x=1$ and $y=0$ yields example 5.1. By simple algebra, condition (3.2) can then be checked with:

$$P(H) = x \frac{B_0(H)}{B_0(H) + B_1(H)}$$

where

$B_0(H)$ = number of pairs of idle neighbors in state H .

$B_1(H)$ = number of pairs of busy neighbors in state H .

Remark

Other randomized examples satisfying the invariance condition (3.2) can be given with features like random gradings, collision detections or losses due to time-slotting (cf. [15]).

EVALUATION

An extension of the standard arrival theorem for closed queueing networks is formulated for communication structures of interdependent sources. It is shown that a product form expression alone is no guarantee for the arrival theorem to be valid. The actual blocking protocol will also be crucial. The results are of practical interest for computational reductions.

REFERENCES

- 1 Boorstyn, R.R., Kershenbaum, A., Maglaris, B. and Sahin, V. (1987), "Throughput Analysis in Multihop CSMA Packet Radio Networks", *IEEE Trans. Commun.*, Com-35, 267-274.
- 2 Brazio, J. and Tobagi, F. (1985), "Conditions for Product Form Solutions in Multihop Packet Radion Networks Modles", *SEL Technical Report 85-274*, Computer Systems Laboratory, Stanford University, Stanford, CA, April 1985.
- 3 Brazio, J. (1987), "Capacity Analysis of Multihop Packet Radio Networks under a General Class of Channel Access Protocols and Capture Models", *Technical Report CLS-TR-87-318*, Computer Systems Laboratory, Stanford University, Stanford, CA, March 1987.
- 4 Burman, D.Y., Lehoczky, J.P. and Lim, Y. (1982), "Insensitivity of Blocking Probabilities in a Circuit Switching Network", *J. Appl. Prob.* 21, 850-859.
- 5 Conway, A.E. and Georganas, N.D. (1989), "Queueing Networks - Exact Computational Algorithms", MIT Press, Cambridge, Massachusetts.
- 6 Conway, A.E., De Souza et Silva, E. and Lavenberg, S.S. (1989), "Mean value analysis by chain of product form queueing networks", *IEEE Trans. Computers*, 38, 432-442.
- 7 Felderman, R.E. (1987), "Extension to the rude-CSMA analysis", *IEEE Trans. Commun.*, Com-35, 848-849.
- 8 Kelly, F.P. (1979), "Reversibility and stochastic networks", Wiley.
- 9 Lam, S.S. (1983), "A simple derivation of the MVA and LBANC algorithms for the convolution algorithm", *IEEE Trans. Computers*, 32, 1062-1064.
- 10 Lavenberg, S.S. and Reiser, M. (1980), "Stationary state probabilities at arrival instants for closed queueing networks with multiple types of customers", *Journal of Applied Probability*, 17(4), 1048-1061.
- 11 Nelson, R. and Kleinrock, L. (1985), "Rude-CSMA: A Multihop Channel Access Protocol", *IEEE Trans. Commun.*, Com-33, 785-791.

- 12 Schweitzer, P.J. (1990), "A survey of mean value analysis, its generalizations and applications for networks of queues", Research report, William E. Simon Graduate School of business Administration, University of Rochester.
- 13 Sevcik, K.C. and Mitrani, I. (1981), "The distribution of queueing network states at input and output instants", *Journal of the ACM*, 29(2): 358-371, April 1981.
- 14 Tobagi, F.A. and Kleinrock, L. (1975), "Packet Switching in Radio Channels; Part II: The Hidden Terminal Problem in Carrier Sense Multiple Access and the Busy Tone Solution", *IEEE Trans. Commun., Com-23*, 1417-1433.
- 15 Van Dijk, N.M. (1988), "Product Forms for Random Access Schemes". To appear: *Computer Networks and ISDN Systems*.
- 16 Van Dijk, N.M. (1990), "An equivalence of communication protocols for interconnection networks", *Computer Networks and ISDN Systems* 20, 277-283.
- 17 Van Dijk, N.M. and Veitkamp, . (1988), "Product Forms for stochastic interference systems", *Probability in Engineering and Informational Sciences* 2, 355-376.
- 18 Zahorjan, J. (1984), "The distribution of network states during residence times in product form queueing networks", *Performance Evaluation*, 4, 99-104.

- 1991-1 N.M. van Dijk On the Effect of Small Loss Probabilities in Input/Output Transmission Delay Systems
- 1991-2 N.M. van Dijk Letters to the Editor: On a Simple Proof of Uniformization for Continuous and Discrete-State Continuous-Time Markov Chains
- 1991-3 N.M. van Dijk
P.G. Taylor An Error Bound for Approximating Discrete Time Servicing by a Processor Sharing Modification
- 1991-4 W. Henderson
C.E.M. Pearce
P.G. Taylor
N.M. van Dijk Insensitivity in Discrete Time Generalized Semi-Markov Processes
- 1991-5 N.M. van Dijk On Error Bound Analysis for Transient Continuous-Time Markov Reward Structures
- 1991-6 N.M. van Dijk On Uniformization for Nonhomogeneous Markov Chains
- 1991-7 N.M. van Dijk Product Forms for Metropolitan Area Networks
- 1991-8 N.M. van Dijk A Product Form Extension for Discrete-Time Communication Protocols
- 1991-9 N.M. van Dijk A Note on Monotonicity in Multicasting
- 1991-10 N.M. van Dijk An Exact Solution for a Finite Slotted Server Model
- 1991-11 N.M. van Dijk On Product Form Approximations for Communication Networks with Losses: Error Bounds
- 1991-12 N.M. van Dijk Simple Performability Bounds for Communication Networks
- 1991-13 N.M. van Dijk Product Forms for Queueing Networks with Limited Clusters
- 1991-14 F.A.G. den Butter Technische Ontwikkeling, Groei en Arbeidsproductiviteit
- 1991-15 J.C.J.M. van den
Bergh, P. Nijkamp Operationalizing Sustainable Development: Dynamic Economic-Ecological Models
- 1991-16 J.C.J.M. van den
Bergh Sustainable Economic Development: An Overview
- 1991-17 J. Barendregt Het mededingingsbeleid in Nederland: Konjunkturgevoeligheid en effectiviteit
- 1991-18 B. Hanzon On the Closure of Several Sets of ARMA and Linear State Space Models with a given Structure
- 1991-19 S. Eijffinger
A. van Rixtel The Japanese Financial System and Monetary Policy: a Descriptive Review
- 1991-20 L.J.G. van Wissen
F. Bonnerman A Dynamic Model of Simultaneous Migration and Labour Market Behaviour