

VU Research Portal

Combinatorial integer labeling theorems on finite sets with applications

van der Laan, G.; Talman, A.J.J.; Yang, Z.

published in

Journal of Optimization Theory and Applications
2010

DOI (link to publisher)

[10.1007/s10957-009-9603-7](https://doi.org/10.1007/s10957-009-9603-7)

document version

Publisher's PDF, also known as Version of record

[Link to publication in VU Research Portal](#)

citation for published version (APA)

van der Laan, G., Talman, A. J. J., & Yang, Z. (2010). Combinatorial integer labeling theorems on finite sets with applications. *Journal of Optimization Theory and Applications*, 144, 391-407. <https://doi.org/10.1007/s10957-009-9603-7>

General rights

Copyright and moral rights for the publications made accessible in the public portal are retained by the authors and/or other copyright owners and it is a condition of accessing publications that users recognise and abide by the legal requirements associated with these rights.

- Users may download and print one copy of any publication from the public portal for the purpose of private study or research.
- You may not further distribute the material or use it for any profit-making activity or commercial gain
- You may freely distribute the URL identifying the publication in the public portal ?

Take down policy

If you believe that this document breaches copyright please contact us providing details, and we will remove access to the work immediately and investigate your claim.

E-mail address:

vuresearchportal.ub@vu.nl

Combinatorial Integer Labeling Theorems on Finite Sets with Applications

G. van der Laan · A.J.J. Talman · Z. Yang

Published online: 18 August 2009

© The Author(s) 2009. This article is published with open access at Springerlink.com

Abstract Tucker's well-known combinatorial lemma states that, for any given symmetric triangulation of the n -dimensional unit cube and for any integer labeling that assigns to each vertex of the triangulation a label from the set $\{\pm 1, \pm 2, \dots, \pm n\}$ with the property that antipodal vertices on the boundary of the cube are assigned opposite labels, the triangulation admits a 1-dimensional simplex whose two vertices have opposite labels. In this paper, we are concerned with an arbitrary finite set D of integral vectors in the n -dimensional Euclidean space and an integer labeling that assigns to each element of D a label from the set $\{\pm 1, \pm 2, \dots, \pm n\}$. Using a constructive approach, we prove two combinatorial theorems of Tucker type. The theorems state that, under some mild conditions, there exists two integral vectors in D having opposite labels and being cell-connected in the sense that both belong to the set $\{0, 1\}^n + q$ for some integral vector q . These theorems are used to show in a constructive way the existence of an integral solution to a system of nonlinear equations under certain natural conditions. An economic application is provided.

Keywords Sperner lemma · Tucker lemma · Integer labeling · Simplicial algorithms · Discrete nonlinear equations

Communicated by F. Zirilli.

G. van der Laan

Department of Econometrics and Tinbergen Institute, VU University Amsterdam,
De Boelelaan 1105, 1081 HV Amsterdam, Netherlands
e-mail: glaan@feweb.vu.nl

A.J.J. Talman (✉)

Center and Department of Econometrics & Operations Research, Tilburg University,
P.O. Box 90153, 5000 LE Tilburg, Netherlands
e-mail: talman@uvt.nl

Z. Yang

Faculty of Business Administration, Yokohama National University, Yokohama 240-8501, Japan
e-mail: yang@ynu.ac.jp

1 Introduction

Fixed-point theorems are fundamental tools for establishing the existence of a solution to various problems in many fields of study such as economics, mathematics and engineering. It is well-known that Brouwer's fixed point theorem is implied by Sperner's combinatorial lemma on the unit simplex and that the Borsuk-Ulam theorem is implied by Tucker's combinatorial lemma on the unit cube.

For any given triangulation of the $(n - 1)$ -dimensional unit simplex $S^n = \{x \in \mathbb{R}_+^n \mid \sum_{i=1}^n x_i = 1\}$, where \mathbb{R}_+^n is the nonnegative orthant of the n -dimensional Euclidean space \mathbb{R}^n , and any given labeling function assigning to every vertex of the triangulation an integer label from the set $\{1, 2, \dots, n\}$, such that a vertex x is not assigned label k whenever $x_k = 0$, Sperner's lemma states that the triangulation contains a completely labeled $(n - 1)$ -dimensional simplex, being a simplex whose n vertices carry all the labels from 1 up to n . In his pioneering work, Scarf [1, 2] gave the first constructive method for finding a completely labeled simplex in Sperner's lemma and thus led to a constructive proof of Brouwer's theorem as well. Later on, more efficient and more flexible simplicial algorithms were developed by Kuhn [3], Eaves [4], Merrill [5], van der Laan and Talman [6] among many others.

Tucker's lemma [7, 8] asserts that for any given symmetric triangulation of the n -dimensional unit cube $C^n = \{x \in \mathbb{R}^n \mid |x_i| \leq 1, i = 1, 2, \dots, n\}$ and any given labeling function assigning to every vertex of the triangulation an integer label from the set $\{\pm 1, \pm 2, \dots, \pm n\}$, such that antipodal vertices of the triangulation on the boundary of C^n are assigned opposite labels (labels that sum to zero), there exists a complementary one-dimensional simplex, i.e., its two vertices have opposite labels. Tucker's lemma implies the famous Borsuk-Ulam antipodal point theorem, a more powerful result than Brouwer's theorem. Based on the $2n$ -ray integer labeling algorithm of van der Laan and Talman [9] and Reiser [10], Freund and Todd [11] have given an elegant constructive proof for Tucker's lemma, and thus a constructive proof of Borsuk-Ulam theorem as well, see also van der Laan [12] and Yang [13].

The combinatorial lemmas of Sperner and Tucker have been extended in various ways. For instance, Fan [14] studied Sperner's lemma in a broader and more abstract setting. Shapley [15] generalized Sperner's lemma by using a set labeling rule instead of an integer labeling rule. Bapat [16] established a permutation-based generalization of Sperner's lemma. Freund [17, 18], van der Laan and Talman [19], Yamamoto [20], and van der Laan, Talman and Yang [21] proved the existence of a completely labeled simplex for an arbitrarily given triangulation of the hypercube, the simplotope and any bounded polyhedron, respectively.

In this paper, we present for the class of finite integrally convex sets several new results on the existence of two vectors in the set having opposite labels and being cell-connected, i.e., both vectors belong to the finite set $\{0, 1\}^n + q$ for some integral vector q . The concept of integrally convex set was introduced by Favati and Tardella [22] and has been well studied in the literature. Many well-known and important integral polyhedra generate integrally convex sets, for instance, the set $P \cap \mathbb{Z}^n$ is integrally convex for any base polyhedron or generalized polymatroid P , where \mathbb{Z}^n is the integer lattice in \mathbb{R}^n . The basic property of an integrally convex set is that its convex hull admits a cubical triangulation for which the set of vertices is equal to

the set itself and every simplex is contained in a cube of size one, i.e., a cell equal to $[0, 1]^n + \{q\}$ for some $q \in \mathbb{Z}^n$.

For a finite integrally convex set D in \mathbb{R}^n and an integer labeling function $\ell : D \rightarrow \{\pm 1, \pm 2, \dots, \pm n\}$, our combinatorial theorems establish the existence of two cell-connected points in D with opposite labels under certain mild conditions. To prove the theorems, we apply the $2n$ -ray integer labeling algorithm of van der Laan and Talman [9] and Reiser [10]. This algorithm, originally developed to approximate a zero point of a continuous function from the n -dimensional unit cube to \mathbb{R}^n , is adapted in such way that it can be used on a cubical triangulation of the convex hull of D . Starting with an arbitrary point in D , the algorithm generates a sequence of adjacent simplices of variable dimension in the triangulation and finds in a finite number of steps a complementary one-dimensional simplex and therefore two cell-connected points with opposite labels. Until now, no such algorithm has been proposed on an arbitrary finite integrally convex set. The combinatorial results in this paper will be used to establish in a constructive way the existence of a solution to a discrete system of nonlinear equations. We also discuss a practical application of these theoretical results.

This paper is organized as follows. In Sect. 2, we present basic concepts and definitions. In Sect. 3, we establish and prove the two main combinatorial labeling theorems. In Sect. 4, we apply these theorems to show the existence of a solution to a discrete system of nonlinear equations. In Sect. 5, an economic application is discussed.

2 Basic Concepts and Definitions

For a given positive integer n , let N denote the set $\{1, 2, \dots, n\}$, \mathbb{R}^n the n -dimensional Euclidean space, and \mathbb{Z}^n the integer lattice of \mathbb{R}^n . For $x, y \in \mathbb{R}^n$, $x \cdot y$ stands for the inner product of x and y . For $i \in N$, $e(i)$ denotes the i th unit vector of \mathbb{R}^n and $e(-i)$ denotes the i th negative unit vector, i.e., $e(-i) = -e(i)$. The symbol 0^n stands for the n -vector of zeroes. A set $X \subseteq \mathbb{R}^n$ is *symmetric* if $x \in X$ implies $-x \in X$. For an arbitrary set $X \subseteq \mathbb{R}^n$, \bar{X} and ∂X denote the convex hull of X and the relative boundary of X , respectively.

Two integral points x and y in \mathbb{Z}^n are *cell-connected* if both x and y belong to the set $\{0, 1\}^n + \{q\}$ for some $q \in \mathbb{Z}^n$. For an integer t , $0 \leq t \leq n$, the t -dimensional convex hull of $t + 1$ affinely independent points x^1, \dots, x^{t+1} in \mathbb{R}^n is a t -simplex or *simplex* and will be denoted by $\sigma(x^1, \dots, x^{t+1})$. The extreme points x^1, \dots, x^{t+1} of a t -simplex $\sigma(x^1, \dots, x^{t+1})$ are the *vertices* of σ . The convex hull of any subset of $k + 1$ vertices of a t -simplex σ , $1 \leq k \leq t$, is a k -dimensional *face* or k -*face* of σ . A k -face of a t -simplex σ is a *facet* of σ if $k = t - 1$, i.e., if the number of vertices is just one less than the number of vertices of the simplex. A simplex is *integral* if all of its vertices are integral vectors, i.e., all vertices are points in \mathbb{Z}^n . An integral simplex is *cubical* if all its vertices lie in a cube $\{0, 1\}^n + \{q\}$ for some $q \in \mathbb{Z}^n$. Notice that any two vertices of a cubical simplex are cell-connected.

Given an m -dimensional convex set X in \mathbb{R}^n , a collection \mathcal{T} of m -dimensional simplices is a *triangulation* of X , if (i) X is the union of all simplices in \mathcal{T} , (ii) the intersection of any two simplices of \mathcal{T} is either empty or a common face of both, and

(iii) any neighborhood of any point in X only meets a finite number of simplices of \mathcal{T} . We refer to Todd [23] and Yang [13] for a more detailed description of triangulations. A triangulation is *cubical* if all its simplices are cubical. A triangulation \mathcal{T} of a symmetric convex set is *symmetric* if $\sigma \in \mathcal{T}$ implies $-\sigma \in \mathcal{T}$.

A set $D \subseteq \mathbb{Z}^n$ is *integrally convex* if (i) $D = \mathbb{Z}^n \cap \overline{D}$ and (ii) the set \overline{D} is a union of cubical simplices. Straightforward examples of integrally convex sets are the sets \mathbb{Z}^n , \mathbb{Z}_+^n , $\{-1, 0, 1\}^n$ and $P \cap \mathbb{Z}^n$ for any base polyhedron or generalized polymatroid P . The concept of integrally convex set was originally introduced by Favati and Tardella [22] and has been well studied in the literature, see Fujishige [24] and Murota [25]. Iimura et al. ([26], Lemma 1) showed that when a set D is integrally convex and thus its convex hull \overline{D} is the union of a collection of cubical simplices, then there exists a collection of cubical simplices that forms a triangulation of \overline{D} . From their proof it also follows that if D is a symmetric integrally convex set, there exists a symmetric cubical triangulation of the convex hull of D . An integrally convex set D in \mathbb{Z}^n is *regular* if \overline{D} is n -dimensional and contains an integral point in its interior. Let

$$\mathcal{I} = \{T \subseteq N \cup (-N) \mid i \in T \text{ implies } -i \notin T\}$$

and, for any $T \in \mathcal{I}$, let $e(T) = \sum_{i \in T} e(i)$. Then, the convex hull of a regular integrally convex set D in \mathbb{Z}^n can be expressed as

$$\overline{D} = \{x \in \mathbb{R}^n \mid e(T) \cdot x \leq b_T \text{ for any } T \in \mathcal{J}\}, \tag{1}$$

for a family $\mathcal{J} \subseteq \mathcal{I}$ and integers b_T , $T \in \mathcal{J}$, so that no constraint is redundant. Further, for any subset \mathcal{K} of \mathcal{J} , define

$$F(\mathcal{K}) = \{x \in \overline{D} \mid e(T) \cdot x = b_T \text{ for all } T \in \mathcal{K}\}.$$

Then either $F(\mathcal{K})$ is empty or it is a face of \overline{D} . A set $\mathcal{K} \subseteq \mathcal{J}$ is *admissible*, when $F(\mathcal{K})$ is a face of \overline{D} . For an admissible set \mathcal{K} , we define $I(\mathcal{K}) = \bigcup_{T \in \mathcal{K}} T$. A vector $w \in \mathbb{R}^n$ is *outgoing* at $x \in D$ if $x + \epsilon w \notin \overline{D}$ for any $\epsilon > 0$. Notice that for $h \in N \cup (-N)$ the vector $e(h)$ is outgoing at $x \in D$ if and only if $h \in I(\mathcal{K})$, where $\mathcal{K} \subseteq \mathcal{J}$ is such that x lies in the relative interior of the face $F(\mathcal{K})$ of \overline{D} . Recall that $F(\emptyset) = \overline{D}$. We conclude this section with two examples.

Example 2.1 Let the set D be given by the set of integral points

$$D = \{x \in \mathbb{Z}^2 \mid -2 \leq x_i \leq 2, \ i = 1, 2, \text{ and } -2 \leq x_1 + x_2 \leq 2\}.$$

Then, D is a finite and regular symmetric integrally convex set. The family \mathcal{J} is given by

$$\mathcal{J} = \{\{1\}, \{-1\}, \{2\}, \{-2\}, \{1, 2\}, \{-1, -2\}\}$$

and $b_T = 2$ for all $T \in \mathcal{J}$. The point $A = (2, 0)^\top$ lies in $F(\{\{1\}, \{1, 2\}\})$, so that $e(1)$ and $e(2)$ are the outgoing unit vectors at A . The point $B = (2, -1)^\top$ lies in (the relative interior of) $F(\{\{1\}\})$, so that $e(1)$ is the only outgoing unit vector at B . Finally, the point $C = (2, -2)^\top$ lies in $F(\{\{1\}, \{-2\}\})$, so that $e(1)$ and $e(-2)$ are the outgoing unit vectors at C . The example is illustrated in Fig. 1.

Fig. 1 Illustration of the discrete set D in Example 2.1

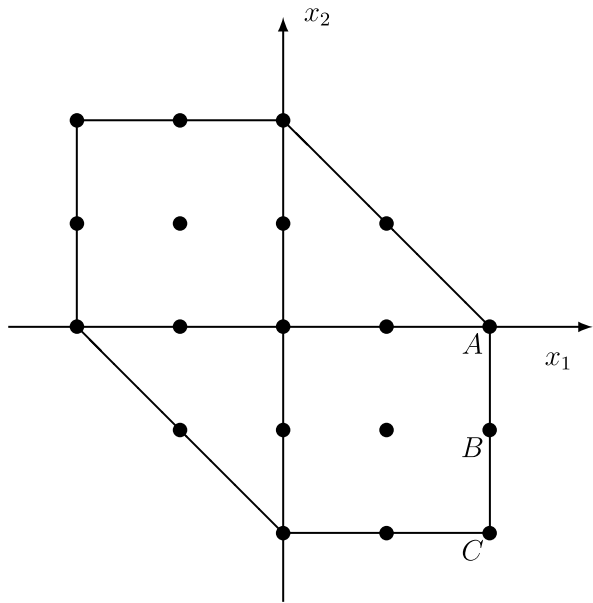
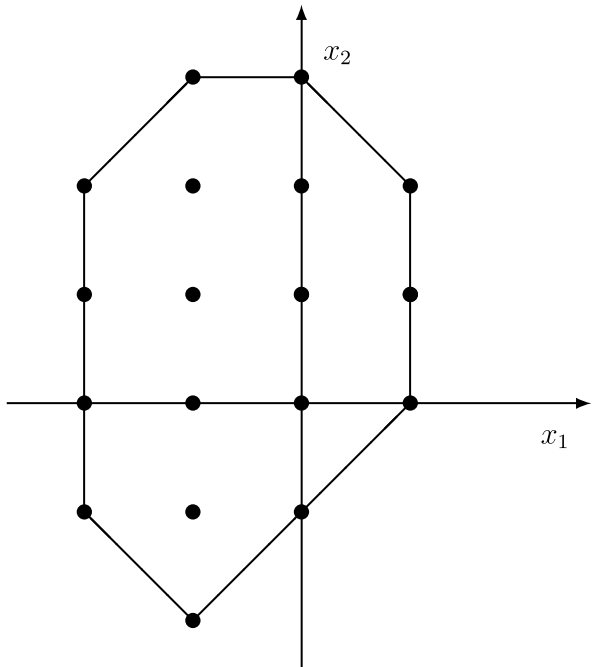

Fig. 2 Illustration of the discrete set D in Example 2.2



Example 2.2 Let the set D be given by the set of integral points

$$D = \{x \in \mathbb{Z}^2 \mid -2 \leq x_1 \leq 1, x_2 \leq 3, -3 \leq x_1 + x_2 \leq 3, -4 \leq x_1 - x_2 \leq 1\}.$$

The set D is a finite and regular integrally convex set. The example is illustrated in Fig. 2. Notice that, for this example, the set D is not symmetric.

3 Combinatorial Integer Labeling Theorems

Given a set $X \subseteq \mathbb{R}^n$ and a finite set of integers K , an integer labeling function $\ell : X \rightarrow K$ assigns to every point in X an element of K ; $\ell(x)$ is called the label of x . When X is an integrally convex set D in \mathbb{Z}^n and $\ell : D \rightarrow N \cup (-N)$ is an integer labeling function, two points $x, y \in D$ are said to be *opposite labeled* if $\ell(x) = -\ell(y)$. We establish two new combinatorial theorems on the existence of two opposite labeled cell-connected points in a finite and regular integrally convex set. The proof of these results is constructive by adapting the $2n$ -ray algorithm of van der Laan and Talman [9] and Reiser [10]. To do so, we first give some preliminaries. For an arbitrarily chosen integral point v in the interior of \overline{D} (since D is regular such a point exists), we define for any $T \in \mathcal{I}$ the set $A(T)$ by

$$A(T) = \{x \in \overline{D} \mid x_i \geq v_i \text{ if } i \in T; x_i \leq v_i \text{ if } -i \in T; \text{ and } x_i = v_i \text{ otherwise}\}.$$

Observe that $A(\emptyset) = \{v\}$ and that $A(T)$ is a t -dimensional convex set for any $T \in \mathcal{I}$, where $t = |T|$. Since D is integrally convex, there exists a cubical triangulation of \overline{D} . Let \mathcal{T} be such a triangulation of \overline{D} . Since \mathcal{T} is cubical, \mathcal{T} induces for every $T \in \mathcal{I}$ a subdivision of $A(T)$ into t -dimensional cubical simplices, with $t = |T|$. Any facet τ of a t -simplex σ in $A(T)$ is either a facet of exactly one other t -simplex σ' in $A(T)$ or lies on the boundary of $A(T)$. In the latter case τ is either a $(t - 1)$ -simplex in $A(T \setminus \{k\})$ for some unique $k \in T$ or a facet in $A(T)$ on the boundary of \overline{D} . Moreover, any t -dimensional simplex in $A(T)$ is cubical and therefore any two vertices of a t -dimensional simplex in $A(T)$ are cell-connected. For a given labeling function $\ell : D \rightarrow N \cup (-N)$ and a set of labels $T \subseteq K$ with $t = |T| \leq n$, a $(t - 1)$ -dimensional simplex τ is said to be *T -complete* if

$$\{\ell(x) \mid x \text{ is a vertex of } \tau\} = T,$$

i.e., the t vertices of τ are differently labeled by the t integers in the set T .

We are now ready to give the first theorem. In this theorem we impose a condition of Sperner type on the labeling function to hold for points in D that lie on the boundary of the convex hull of D .

Theorem 3.1 *Let D be a finite and regular integrally convex set in \mathbb{Z}^n and let $\ell : D \rightarrow N \cup (-N)$ be an integer labeling function such that, for any admissible set $\mathcal{K} \subseteq \mathcal{J}$ and integral boundary point $x \in F(\mathcal{K}) \cap D$, it holds that $\ell(x) \notin I(\mathcal{K})$. Then, D contains two opposite labeled cell-connected points.*

To prove Theorem 3.1, we need the following lemma, stating that no facet of a simplex in $A(T)$ on the boundary of \overline{D} can be T -complete.

Lemma 3.1 *When the integer labeling function $\ell : D \rightarrow N \cup (-N)$ satisfies the boundary condition of Theorem 3.1, there does not exist a T -complete facet in $A(T) \cap \partial \overline{D}$ for any $T \in \mathcal{I}$.*

Proof Suppose that τ is a T -complete facet in $A(T)$ for some $T \in \mathcal{I}$ and that τ lies on the boundary of \overline{D} . Then $\tau \subseteq A(T) \cap F(\mathcal{K})$ for some minimal admissible set $\mathcal{K} \subseteq \mathcal{J}$.

We will first show that $T \cap I(\mathcal{K}) \neq \emptyset$. Suppose to the contrary that $T \cap I(\mathcal{K}) = \emptyset$. Take any point x in the relative interior of τ . Clearly, x is in the relative interior of $F(\mathcal{K})$. Since $T \cap I(\mathcal{K}) = \emptyset$, there exists $\bar{\epsilon} > 0$ such that, for any $\epsilon, 0 \leq \epsilon \leq \bar{\epsilon}$,

$$x + \epsilon e(h) \in \bar{D}, \quad \text{for all } h \in T.$$

Furthermore, since x is in the interior of τ and τ cannot lie in $A(T \setminus \{h\})$ for any $h \in T$, there exist unique $\lambda_i > 0, i \in T$, such that

$$x = v + \sum_{i \in T} \lambda_i e(i).$$

For $i \in T$, let μ_i be equal to

$$\mu_i = \lambda_i / \sum_{j \in T} \lambda_j,$$

and, for some $\epsilon, 0 \leq \epsilon \leq \bar{\epsilon}$, let

$$y = x + \epsilon \sum_{i \in T} \mu_i e(i).$$

Then, the point

$$y = \sum_{h \in T} \mu_h(x + \epsilon e(h))$$

is a convex combination of elements of \bar{D} . Since \bar{D} is a convex set, $y \in \bar{D}$. On the other hand, it holds that $x = \lambda v + (1 - \lambda)y$ for some $0 < \lambda < 1$. Since v is in the interior of \bar{D} and y is in \bar{D} , the point x must lie in the interior of \bar{D} , contradicting that x lies on the boundary of \bar{D} . Consequently, $T \cap I(\mathcal{K}) \neq \emptyset$. Take any $k \in T \cap I(\mathcal{K})$. Since τ is T -complete, some vertex y of τ carries label k , but the boundary condition implies that no vertex of τ is labeled with k . This yields a contradiction. Therefore there can be no T -complete facet of a simplex in $A(T)$ lying in $\partial \bar{D}$. \square

We now give a constructive proof of Theorem 3.1 by applying the $2n$ -ray algorithm of van der Laan and Talman [9] and Reiser [10].

Proof of Theorem 3.1 Let $\ell(v)$ be the label of the point v . Then, with $T = \{\ell(v)\}$, $\{v\}$ in $A(\emptyset)$ is a T -complete 0-dimensional facet of the unique 1-dimensional simplex $\sigma^0 = \sigma(x^1, x^2)$ in $A(T)$ with vertices $x^1 = v$ and $x^2 = v + e(\ell(v))$. The $2n$ -ray algorithm starts from σ^0 with $T = \{\ell(v)\}$ and generates, for varying sets $T \in \mathcal{I}$, a sequence of adjacent t -simplices in $A(T)$ with T -complete common facets, where $t = |T|$. When the algorithm encounters a t -simplex σ in $A(T)$ having a vertex carrying a label k for some $k \notin T \cup (-T)$, then k is added to T and the algorithm continues in $A(T \cup \{k\})$ with the unique $(t + 1)$ -simplex in $A(T \cup \{k\})$ having σ as its facet. When the algorithm generates in $A(T)$ a T -complete facet τ lying in $A(T \setminus \{k\})$ for some $k \in T$, then k is deleted from T and the algorithm continues in $A(T \setminus \{k\})$ with the facet opposite the vertex of τ carrying label k . The algorithm terminates if

either it generates in $A(T)$ a T -complete facet τ in the boundary $A(T) \cap \partial \overline{D}$ or it encounters a vertex carrying label $-k$ for some $k \in T$. Since the initial simplex σ^0 is uniquely determined and every other simplex generated by the algorithm has a unique predecessor and in case it doesn't satisfy one of the stopping properties stated above has a unique successor, it follows by the well-known Lemke-Howson argument that a simplex will never be visited more than once, see van der Laan and Talman [9] for a more detailed description. Since the number of simplices in the triangulation of \overline{D} is finite, the algorithm will terminate with a simplex which has one of the stopping properties. However, by Lemma 3.1 it can not happen that the algorithm generates in $A(T)$ a T -complete facet τ in the boundary $A(T) \cap \partial \overline{D}$ for any T . Therefore, the algorithm terminates with a cubical simplex having two vertices with labels k and $-k$ for some $k \in N$ and thus finds within a finite number of steps two opposite labeled cell-connected points in D . \square

Theorem 3.1 is illustrated in Fig. 3, in which the discrete set D is the same as that given in Fig. 1. The boundary condition requires that the labels 1 and 2 do not occur on the line from $(2, 0)$ to $(0, 2)$, indeed the labels of the three integer points on this line are -1 or -2 . Also the labels of the integer points on the line from $(2, 0)$ to $(2, -2)$ satisfy the requirement that on this line the label 1 should not occur. Similarly it is easy to verify that all labels of the integer points on the boundary of the set \overline{D} satisfy the labeling requirement. Therefore, according to the theorem, there are two cell-connected points, namely $(0, 0)$ and $(0, 1)$, having the opposite labels 2 and -2 .

Theorem 3.1 holds for any finite (regular) integrally convex set D , i.e., for any finite set D of integral points for which the convex hull \overline{D} is a polyhedron as described in formula (1) and any integral point of \overline{D} belongs to D itself. A special case is that

Fig. 3 Illustration of Theorem 3.1

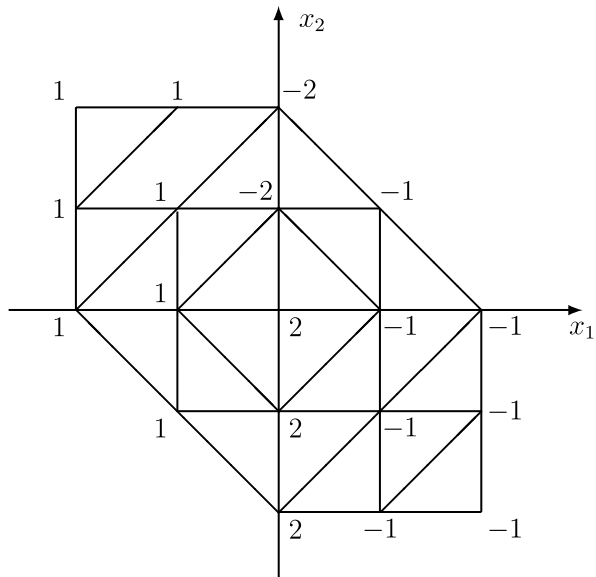

\overline{D} is an n -dimensional rectangular or cube given by

$$\overline{D} = C^n(a, b) = \{x \in \mathbb{R}^n \mid a_i \leq x_i \leq b_i, i \in N\},$$

where a, b are two integral n -vectors satisfying $b_i > a_i + 1$ for all $i \in N$. In this case, the boundary condition of the labeling function reduces to $\ell(x) \neq -i$ whenever $x_i = a_i$ and $\ell(x) \neq i$ whenever $x_i = b_i$. We now have the following corollary, see also Freund [17].

Corollary 3.1 *Let the set D be given by $D = \{x \in \mathbb{Z}^n \mid a_i \leq x_i \leq b_i, i \in N\}$, for some vectors $a, b \in \mathbb{Z}^n$ satisfying $b_i > a_i + 1$ for all $i \in N$, and let $\ell : D \rightarrow N \cup (-N)$ be an integer labeling function such that $\ell(x) \neq -i$ if $x_i = a_i$ and $\ell(x) \neq i$ if $x_i = b_i$. Then, D contains two opposite labeled cell-connected points.*

The following corollary follows immediately from Theorem 3.1 by observing that when the boundary condition is not satisfied the algorithm either ends with two opposite labeled cell-connected points in D or with a T -complete facet in $A(T) \cap \partial \overline{D}$ for some T . According to the proof of Lemma 3.1, in the latter case we must have that for at least one element $k \in T$ it holds that $e(k)$ is an outgoing vector at τ .

Corollary 3.2 *Let $D \subseteq \mathbb{Z}^n$ be a finite and regular integrally convex set and let $\ell : D \rightarrow N \cup (-N)$ be an arbitrary integer labeling function. Then, D contains two opposite labeled cell-connected points or a point x in the boundary of \overline{D} such that, for some $k \in N \cup (-N)$, $\ell(x) = k$ and $e(k)$ is an outgoing vector at x .*

The next corollary follows immediately by applying the previous corollary and Theorem 3.1 to the integer labeling function $\tilde{\ell} : D \rightarrow N \cup (-N)$ given by $\tilde{\ell}(x) = -\ell(x)$ for all $x \in D$.

Corollary 3.3 *Let $D \subseteq \mathbb{Z}^n$ be a finite and regular integrally convex set and let $\ell : D \rightarrow N \cup (-N)$ be an arbitrary integer labeling function. Then, D contains two opposite labeled cell-connected points or a point x in the boundary of \overline{D} such that, for some $k \in N \cup (-N)$, $\ell(x) = k$ and $e(-k)$ is an outgoing vector at x . Moreover, when ℓ is such that for any admissible set $\mathcal{K} \subseteq \mathcal{J}$ and integral boundary point $x \in F(\mathcal{K}) \cap D$ it holds that $\ell(x) \neq -k$ for any $k \in I(\mathcal{K})$, then D contains two opposite labeled cell-connected points.*

We now state our second major existence theorem. This theorem generalizes the well-known Tucker’s lemma to a finite and regular, symmetric integrally convex set. To prove the theorem we adapt the $2n$ -algorithm in such a way that when a T -complete facet τ in $A(T)$ on the boundary of \overline{D} is generated, the algorithm continues with the $(-T)$ -complete facet $-\tau$ in $A(-T)$. This step is called *the reflection step* and is originally due to Freund and Todd (1981) who modified the original $2n$ -ray algorithm of van der Laan and Talman [9] and Reiser [10] to provide a constructive proof for Tucker’s lemma.

Theorem 3.2 *Let $D \subseteq \mathbb{Z}^n$ be a finite, regular and symmetric integrally convex set and let $\ell : D \rightarrow N \cup (-N)$ be an integer labeling function such that for any $x \in \partial \overline{D} \cap D$, $\ell(-x) = -\ell(x)$. Then, the set D contains two opposite labeled cell-connected points.*

Proof Since D is regular, integrally convex and symmetric, there exists a symmetric cubical triangulation \mathcal{T} of \overline{D} . Moreover, the origin 0^n is an element of D and lies in the interior of \overline{D} . We take the origin as the starting point v of the $2n$ -algorithm, i.e., for any $T \in \mathcal{I}$, the set $A(T)$ is defined by

$$A(T) = \{x \in \overline{D} \mid x_i \geq 0 \text{ if } i \in T; x_i \leq 0 \text{ if } -i \in T; \text{ and } x_i = 0, \text{ otherwise}\}.$$

Since \mathcal{T} is cubical, \mathcal{T} induces for every $T \in \mathcal{I}$ a subdivision of $A(T)$ into t -dimensional cubical simplices, where $t = |T|$. Moreover, by the symmetry of D it follows that $A(-T) = -A(T)$ and by the symmetry of \mathcal{T} that if σ is a t -dimensional simplex in $A(T)$, then $-\sigma$ is a t -dimensional simplex in $A(-T)$. In particular it holds that when τ is a facet of a t -dimensional simplex in $A(T)$ lying on the boundary of \overline{D} , then $-\tau$ also lies on the boundary of \overline{D} and is a facet of precisely one t -dimensional simplex in $A(-T)$.

The algorithm starts with the unique 1-dimensional simplex σ^0 in $A(T)$ having 0^n as vertex, where $T = \{\ell(0^n)\}$, and generates in the same way as in the proof of Theorem 3.1 a sequence of adjacent t -simplices in $A(T)$ with T -complete common facets for varying $T \in \mathcal{I}$, with the only difference that when a T -complete facet τ of a simplex in $A(T)$ is generated that lies on the boundary of \overline{D} , then a reflection step is made, i.e., the set T of labels becomes $-T$ and the algorithm jumps from τ to $-\tau$ and continues with the unique simplex in $A(-T)$ having $-\tau$ as its facet in order to generate adjacent t -simplices in $A(-T)$ with $(-T)$ -complete common facets. Again each step of the algorithm is uniquely determined and it follows by the Lemke-Howson argument that no simplex can be visited more than once. Since D is finite and thus \overline{D} is bounded, the number of simplices is finite. Therefore the algorithm terminates within a finite number of steps with a simplex in \mathcal{T} having two opposite labeled vertices. Since any simplex in \mathcal{T} is cubical, these two vertices are cell-connected. \square

4 Solving Discrete Systems of Nonlinear Equations

Many problems arising from economics, game theory, engineering and other fields are formulated as a system of nonlinear equations. The most widely used tool for showing the existence of a solution to the system is Brouwer's and Kakutani's fixed-point theorems. Brouwer's theorem states that a continuous function from a convex and compact subset of \mathbb{R}^n to itself leaves one point fixed. The latter one generalizes the former to upper semicontinuous point-to-set mappings.

In many circumstances, for example, when the domain of interest is a discrete set or the presence of indivisibility in an economic model is significant, the continuity (upper semicontinuity) or convexity requirement of Brouwer's (Kakutani's) theorem is no longer fulfilled; see e.g., Kelso and Crawford [27], Fudenberg and Tirole [28], Scarf [29], Gul and Stacchetti [30], Sun and Yang [31]. The purpose of this section

is to investigate (i) what conditions guarantee the existence of a solution to a discrete system of nonlinear equations

$$f_i(x_1, \dots, x_n) = 0, \quad i = 1, \dots, n, \tag{2}$$

where $f = (f_1, f_2, \dots, f_n)^\top$ is a function from \mathbb{Z}^n to \mathbb{R}^n , and (ii) how to find a solution, if it exists. A solution to the system (2) is also called a *discrete zero point* of f . In the last few years several authors have obtained results on this topic mainly for functions that are *direction preserving* (see Iimura et al. [26], Danilov and Koshevoy [32]) or *locally gross direction preserving* (see Yang [33, 34] and van der Laan et al. [35–37]).

In this section, we establish two existence theorems for the system (2) that are built upon the class of simplicially positive maximum component sign preserving functions introduced by Talman and Yang [38].

Definition 4.1 Let $D \subseteq \mathbb{Z}^n$ be an integrally convex set. A function $f : D \rightarrow \mathbb{R}^n$ is *simplicially positive maximum component sign preserving* if there exists a cubical triangulation \mathcal{T} of \overline{D} such that, for any two vertices x and y of a simplex of \mathcal{T} , $f_j(x) = \max_{h \in N} f_h(x) > 0$ implies $f_j(y) \geq 0$.

The first theorem is a discrete analogue of Brouwer’s fixed-point theorem by observing that a zero point of f is a fixed-point of the function g given by $g(x) = f(x) + x$.

Theorem 4.1 Let $D \subseteq \mathbb{Z}^n$ be a finite and regular integrally convex set and let $f : D \rightarrow \mathbb{R}^n$ be a simplicially positive maximum component sign preserving function. Assume that, for any $x \in \partial \overline{D} \cap D$ with $f(x) \neq 0^n$, $f_h(x) < \max_{i \in N} |f_i(x)|$ if $e(h)$ is outgoing at x for some $h \in N$, and $f_h(x) > -\max_{i \in N} |f_i(x)|$ if $e(-h)$ is outgoing at x for some $h \in N$. Then, f has a discrete zero point in D .

To prove Theorem 4.1, we assign to each point x of the set D an integer from the set $N \cup (-N) \cup \{0\}$. The labeling rule is induced from the function f as follows. For given $x \in D$, let k be any element in N such that $|f_k(x)| = \max_{h \in N} |f_h(x)|$. Then, $\ell(x) = 0$ if $f_k(x) = 0$, $\ell(x) = k$ if $f_k(x) > 0$ and $\ell(x) = -k$ if $f_k(x) < 0$. Observe that $\ell(x) = 0$ if and only if $f(x) = 0^n$.

The following lemma shows that this integer labeling rule excludes the possibility that any two cell-connected points are opposite labeled when the function satisfies the simplicially positive maximum component sign preserving property.

Lemma 4.1 Let $f : D \rightarrow \mathbb{R}^n$ be a simplicially positive maximum component sign preserving function with respect to some cubical triangulation \mathcal{T} of \overline{D} . Then, there exists no simplex in \mathcal{T} carrying both labels k and $-k$ for some $k \in N$.

Proof Suppose to the contrary that there is a simplex in \mathcal{T} carrying labels k and $-k$ for some $k \in N$. Then for the vertex x with label k we have $f_k(x) = \max_h |f_h(x)| > 0$, while for the vertex y with label $-k$ we have $f_k(y) = -\max_h |f_h(y)| < 0$. Since

x and y are in the same simplex, this contradicts the simplicially positive maximum component sign preserving property of the function f . \square

Proof of Theorem 4.1 Let \mathcal{T} be the underlying cubical triangulation of \overline{D} and let ℓ be the integer labeling function on D induced by f . From the boundary condition that for every $h \in N$ it holds that $f_h(x) < \max_{i \in N} |f_i(x)|$ if $e(h)$ is outgoing at x and that $f_h(x) > -\max_{i \in N} |f_i(x)|$ if $e(-h)$ is outgoing at x for any $x \in \partial \overline{D} \cap D$ with $f(x) \neq 0^n$, it follows that the labeling function ℓ satisfies the boundary condition of Theorem 3.1 for any $x \in \partial \overline{D} \cap D$ satisfying $f(x) \neq 0^n$. Suppose that the function f has no discrete zero point and thus $\ell(x) \neq 0$ for any $x \in D$. Then it follows from Theorem 3.1 that there exists two cell-connected integral points with opposite labels. However, this contradicts Lemma 4.1. Hence, there must be a point in D with label 0, which proves the existence of a discrete zero point of f in D . \square

Theorem 4.1 is illustrated in the following example.

Example 4.1 Consider the function $f : D \rightarrow \mathbb{R}^2$ given by $f(x) = (-2x_1, 1 - x_2 - x_1)$, where D is the discrete set as given in Example 2.1. It is easy to verify that f indeed is a simplicially positive maximum component sign preserving function on D with the cubical triangulation as pictured in Fig. 4. Furthermore, the function satisfies the boundary condition of Theorem 4.1. Figure 4 also shows the labels of the points of D induced by f . The unique discrete zero point $(0, 1)$ of f carries label 0.

The next theorem is a discrete analogue of the famous Borsuk-Ulam theorem on the cube; see Freund and Todd [11], van der Laan [12] and Yang [13].

Fig. 4 Illustration of Example 4.1

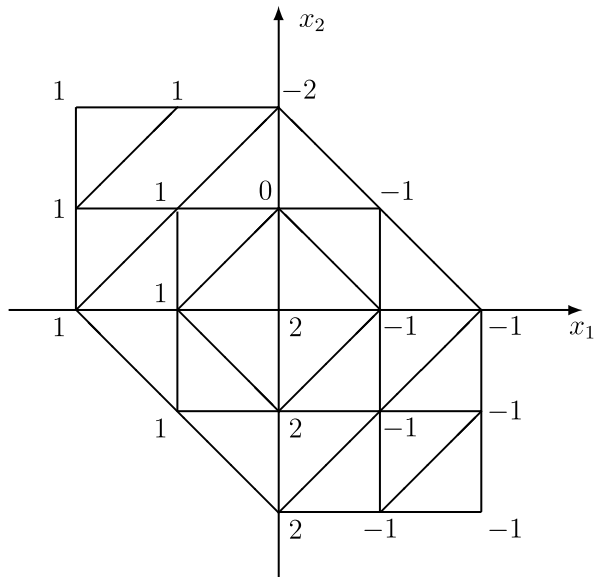

Theorem 4.2 *Let $D \subseteq \mathbb{Z}^n$ be a finite, regular and symmetric integrally convex set and let $f : D \rightarrow \mathbb{R}^n$ be a simplicially positive maximum component sign preserving function with respect to some symmetric cubical triangulation of \overline{D} such that, for any $x \in \partial \overline{D} \cap D$, there exists some $k \in N$ such that $f_k(x)f_k(-x) = -\max_{i \in N} |f_i(x)| \max_{i \in N} |f_i(-x)|$. Then, f has a discrete zero point in D .*

To prove Theorem 4.2, we adapt for an integral point x on the boundary of \overline{D} the labeling $\ell(x)$ as follows. When $f(x) = 0^n$ or $f(-x) = 0^n$, $\ell(x)$ is the label induced by f as above. When both $f(x) \neq 0^n$ and $f(-x) \neq 0^n$, take any $k \in N$ such that $f_k(x)f_k(-x) = -\max_{i \in N} |f_i(x)| \max_{i \in N} |f_i(-x)|$. Then we take $\ell(x) = k$ if $f_k(x) > 0$ and $\ell(x) = -k$ if $f_k(x) < 0$. Clearly, the labeling rule $\ell(\cdot)$ satisfies that two antipodal points on the boundary of \overline{D} either have opposite labels or at least one of the two points has label 0. The next lemma shows that no two vertices of some simplex can have opposite labels.

Lemma 4.2 *Let $D \subseteq \mathbb{Z}^n$ be a finite, regular and symmetric integrally convex set and let $f : D \rightarrow \mathbb{R}^n$ be a function satisfying the conditions of Theorem 4.2 with respect to some symmetric cubical triangulation \mathcal{T} of \overline{D} . Then, for the modified integer labeling function induced by f , there exists no simplex in \mathcal{T} carrying both labels k and $-k$ for some $k \in N$.*

Proof Let $\ell(\cdot)$ be the modified integer labeling function induced by f on D and let x and y be two vertices of any simplex of \mathcal{T} . When both x and y are in the interior of \overline{D} , then it follows similarly as in the proof of Lemma 4.1, that x and y can not have opposite labels. Next, let x be a vertex on the boundary of \overline{D} with $\ell(x) \neq 0$. Without loss of generality, suppose that $\ell(x) = k$ for some $k \in N$. From the labeling rule it follows that $f_k(x) > 0$ and $f_k(x)f_k(-x) = -\max_{i \in N} |f_i(x)| \max_{i \in N} |f_i(-x)|$. This implies that $f_k(x) = \max_{h \in N} |f_h(x)|$. We now consider two cases. First, when y is in the interior of \overline{D} , it follows by the simplicially positive maximum component sign preserving condition that y can not have label $-k$. The second case is that also y is on the boundary of \overline{D} . Since D is regular and thus has an interior point, two opposite points on the boundary can not belong to the same cell and therefore also not to the same simplex of \mathcal{T} . Hence, y is not opposite to x , i.e., $y \neq -x$. Suppose that y has label $-k$. Then, by the labeling rule we must have $f_k(y) < 0$, contradicting the simplicially positive maximum component sign preserving condition on f . \square

Proof of Theorem 4.2 Let \mathcal{T} be the underlying symmetric cubical triangulation of \overline{D} with respect to f and let $\ell(\cdot)$ be the modified integer label function on D induced by f . Suppose that the function f has no discrete zero point at all, thus $\ell(x) \neq 0$ for any $x \in D$. Then $\ell(\cdot)$ satisfies the boundary condition of Theorem 3.2 and thus there exists two cell-connected integral points with opposite labels. However, this contradicts Lemma 4.2. Hence, f must have a discrete zero point in D . \square

5 Economic Application

In this section, we discuss an economical application of Theorem 4.1, namely the Cournot oligopoly model with complementary commodities, see for instance Fuden-

berg and Tirole [28] or Vives [39]. We first describe the classical version of this model in which all goods are assumed to be perfectly divisible. There are n firms, each firm producing its own commodity. The goal of each firm is to choose an amount of product that maximizes its own profit given the production levels chosen by other firms. Let $N = \{1, \dots, n\}$ denote the set of firms. Assume that firm i produces commodity i . For $i \in N$, let $q_i \geq 0$ denote the quantity of commodity i produced by firm i , and let $q_{-i} = (q_1, \dots, q_{i-1}, q_{i+1}, \dots, q_n)$ denote the $(n - 1)$ -vector of nonnegative quantities produced by the firms other than firm i . The price p_i at which firm $i \in N$ can sell its product is decreasing in its own quantity q_i and, due to complementarities between the commodities, is assumed to be increasing in the quantities $q_j, j \neq i$, of the other firms. It is standard to assume that all price functions are linear, i.e., given the quantities $q_j, j \neq i$, producer i can sell its own quantity q_i at price

$$p_i = P_i(q_i, q_{-i}) = a_i - b_i q_i + \sum_{j \neq i} d_{ij} q_j, \quad i = 1, \dots, n,$$

where all parameters a_i, b_i, d_{ij} are positive. Each firm $i \in N$ has a linear cost function $C_i(q_i) = c_i q_i$ with $a_i > c_i > 0$. For quantities (q_1, \dots, q_n) , the profit π_i of firm $i \in N$ is given by

$$\pi_i(q_i, q_{-i}) = q_i P_i(q_i, q_{-i}) - c_i q_i.$$

A tuple $(q_1^*, q_2^*, \dots, q_n^*) \in \mathbb{R}_+^n$ of nonnegative real numbers is a *Cournot-Nash equilibrium* if, for every firm $i \in N$,

$$\pi_i(q_i^*, q_{-i}^*) \geq \pi_i(q_i, q_{-i}^*), \quad \text{for all } q_i \in \mathbb{R}_+.$$

It is well-known that there exists a Cournot-Nash equilibrium if $2b_i > \sum_{j \neq i} d_{ij}$ for every firm $i = 1, \dots, n$.

In many practical situations the assumption that all commodities are perfectly divisible cannot be satisfied. In fact, it is typically the case that the commodities are produced and sold in integer quantities, for example, when they are inherently indivisible, such as cars, machines or houses. Also many divisible goods are sold in discrete quantities, like barrels of oil or grain. Therefore it is important to know whether there exists a discrete Cournot-Nash equilibrium.

A tuple $(q_1^*, q_2^*, \dots, q_n^*) \in \mathbb{Z}_+^n$ of nonnegative integers is a *discrete Cournot-Nash equilibrium* if, for every firm $i \in N$,

$$\pi_i(q_i^*, q_{-i}^*) \geq \pi_i(q_i, q_{-i}^*), \quad \text{for all } q_i \in \mathbb{Z}_+.$$

That is, given the integer quantities chosen by other firms, each firm chooses an integer quantity that yields a profit which is at least as high as any other integer quantity could give.

For a real number x , the symbol $[x]$ denotes the greatest nearest integer to x . Given nonnegative integer quantities q_{-i} of all other firms, each firm $i \in N$ maximizes its profit $\pi_i(q_i, q_{-i})$ over all nonnegative integers q_i , and its optimal integer quantity is

given by the reaction function

$$r_i(q_{-i}) = \left[\frac{a_i - c_i}{2b_i} + \sum_{j \neq i} \frac{d_{ij}}{2b_i} q_j \right].$$

Observe that for any $i \in N$ it holds that $r_i(q_{-i}) \geq 0$ for all $q \in \mathbb{Z}_+^n$, because $a_i > c_i > 0$. Finally, define the function $f : \mathbb{Z}_+^n \rightarrow \mathbb{Z}^n$ by

$$f_i(q_i, q_{-i}) = r_i(q_{-i}) - q_i, \quad i = 1, \dots, n.$$

Clearly, a discrete zero point of f is a discrete Cournot-Nash equilibrium.

Theorem 5.1 *The Cournot oligopoly model with complementary commodities has a discrete Cournot-Nash equilibrium when $2b_i > \sum_{j \neq i} d_{ij}$, $i = 1, \dots, n$.*

Proof We show that the function f satisfies the conditions of Theorem 4.1 for the discrete set $D = \{x \in \mathbb{Z}^n \mid 0 \leq x_i \leq M, i = 1, \dots, n\}$, where $M > 1$ is an integer satisfying $M > \max_i \left\{ \frac{a_i - c_i}{2b_i - \sum_{j \neq i} d_{ij}} \right\}$. First, for any $i \in N$ and $q \in \mathbb{Z}_+^n$, $q_i = 0$ implies $f_i(q) = r_i(q_{-i}) \geq 0$. Also, for any $i \in N$ and $q \in \mathbb{Z}_+^n$, $q_i = M$ and $q_j \leq M, j \neq i$, imply

$$\begin{aligned} f_i(q) &= \left[\frac{a_i - c_i}{2b_i} + \sum_{j \neq i} \frac{d_{ij}}{2b_i} q_j - q_i \right] \\ &\leq \left[\frac{a_i - c_i}{2b_i} + \sum_{j \neq i} \frac{d_{ij}}{2b_i} M - M \right] \\ &\leq \left[\frac{a_i - c_i - (2b_i - \sum_{j \neq i} d_{ij})M}{2b_i} \right] \leq 0, \end{aligned}$$

where the last inequality follows from the fact that

$$M > \frac{a_i - c_i}{2b_i - \sum_{j \neq i} d_{ij}}.$$

So, the function f satisfies the boundary conditions of Theorem 4.1 on the discrete set D .

Second, we show that f is simplicially positive maximum component sign preserving with respect to the well-known K -triangulation of \mathbb{R}^n with grid size 1. The K -triangulation of \mathbb{R}^n with grid size 1 is the collection of integral simplices $\sigma(y, \pi)$ with vertices y^1, \dots, y^{n+1} , with $y^1 = y$ and $y^{i+1} = y^i + e(\pi(i))$, $i = 1, \dots, n$ for any $y \in \mathbb{Z}^n$ and permutation $\pi = (\pi(1), \dots, \pi(n))$ of the elements in N . We have to verify that $f_j(x) = \max_{h \in N} f_h(x) > 0$ implies $f_j(y) \geq 0$ for any pair x, y with $x \in \mathbb{Z}_+^n$ and $y = x + \sum_{h=1}^k e(\pi(h))$ for $k = 1, \dots, n$, and any permutation π . To establish this, it is sufficient to prove that $f_i(x)f_i(y) \geq 0$ for all $i \in N$. Observe that for

any such pair x and y it holds that $y_j \in \{x_j, x_j + 1\}$ for all $j \in N$. Take any such pair of points x and y and any $i \in N$, and let $S_i(x, y) = \{j \neq i \mid y_j = x_j + 1\}$. Then,

$$r_i(y) = \left[\frac{a_i - c_i}{2b_i} + \sum_{j \neq i} \frac{d_{ij}}{2b_i} y_j \right] = \left[\frac{a_i - c_i}{2b_i} + \sum_{j \neq i} \frac{d_{ij}}{2b_i} x_j + \sum_{j \in S_i(x, y)} \frac{d_{ij}}{2b_i} \right].$$

Since $\sum_{j \neq i} \frac{d_{ij}}{2b_i} < 1$, it follows that $r_i(y) \in \{r_i(x), r_i(x) + 1\}$. Hence, since $y_i \in \{x_i, x_i + 1\}$, it follows that

$$f_i(y) \in \{f_i(x) - 1, f_i(x), f_i(x) + 1\}.$$

So, $f_i(x) \geq 1$ implies $f_i(y) \geq f_i(x) - 1 \geq 0$; and $f_i(x) \leq -1$ implies $f_i(y) \leq f_i(x) + 1 \leq 0$. In summary, $f_i(x)f_i(y) \geq 0$ for all i .

We have shown that f satisfies all the conditions of Theorem 4.1 and thus has a discrete zero point. As a result, there is a discrete Cournot-Nash equilibrium. \square

Acknowledgements The third author gratefully acknowledges financial support by the Ministry of Education, Science, and Technology of Japan, by the Netherlands Organization for Scientific Research (NWO), and by the National Natural Science Foundation of China (#10771042).

Open Access This article is distributed under the terms of the Creative Commons Attribution Noncommercial License which permits any noncommercial use, distribution, and reproduction in any medium, provided the original author(s) and source are credited.

References

1. Scarf, H.: The approximation of fixed points of a continuous mapping. *SIAM J. Appl. Math.* **15**, 1328–1343 (1967)
2. Scarf, H.: *The Computation of Economic Equilibria*. Yale University Press, New Haven (1973)
3. Kuhn, H.W.: Simplicial approximation of fixed points. *Proc. Natl. Acad. Sci.* **61**, 1238–1242 (1969)
4. Eaves, B.C.: Homotopies for computation of fixed points. *Math. Program.* **3**, 1–22 (1972)
5. Merrill, O.H.: Applications and extensions of an algorithm that computes fixed points of certain upper semi-continuous point-to-set mappings. PhD Thesis, University of Michigan, Ann Arbor (1972)
6. van der Laan, G., Talman, A.J.J.: A restart algorithm for computing fixed points without an extra dimension. *Math. Program.* **17**, 74–84 (1979)
7. Tucker, A.W.: Some topological properties of disk and sphere. In: *Proceedings of the First Canadian Mathematical Congress, Montreal*, pp. 285–309 (1945)
8. Lefschetz, S.: *Introduction to Topology*. Princeton University Press, Princeton (1949)
9. van der Laan, G., Talman, A.J.J.: A class of simplicial restart fixed point algorithms without an extra dimension. *Math. Program.* **20**, 33–48 (1981)
10. Reiser, P.M.: A modified integer labeling for complementarity algorithms. *Math. Oper. Res.* **6**, 129–139 (1981)
11. Freund, R.M., Todd, M.J.: A constructive proof of Tucker's combinatorial lemma. *J. Comb. Theory* **30**, 321–325 (1981)
12. van der Laan, G.: On the existence and approximation of zeros. *Math. Program.* **28**, 1–14 (1984)
13. Yang, Z.: *Computing Equilibria and Fixed Points*. Kluwer, Boston (1999)
14. Fan, K.: Simplicial maps from an orientable n -pseudomanifold into S^m with the octahedral triangulation. *J. Comb. Theory* **2**, 588–602 (1967)
15. Shapley, L.S.: On balanced games without side payments. In: Hu, T.C., Robinson, S.M. (eds.) *Mathematical Programming*, pp. 261–290. Academic Press, New York (1973)
16. Bapat, R.B.: A constructive proof of a permutation-based generalization of Sperner's lemma. *Math. Program.* **44**, 113–120 (1989)

17. Freund, R.M.: Combinatorial theorems on the simplotope that generalize results on the simplex and cube. *Math. Oper. Res.* **11**, 169–179 (1986)
18. Freund, R.M.: Combinatorial analogs of Brouwer's fixed point theorem on a bounded polyhedron. *J. Comb. Theory, Ser. B* **2**, 192–219 (1989)
19. van der Laan, G., Talman, A.J.J.: On the computation of fixed points in the product space of unit simplices and an application to noncooperative N-person game. *Math. Oper. Res.* **7**, 1–13 (1982)
20. Yamamoto, Y.: Orientability of a pseudomanifold and generalization of Sperner's lemma. *J. Oper. Res. Soc. Jpn.* **31**, 19–42 (1988)
21. van der Laan, G., Talman, A.J.J., Yang, Z.: Existence of balanced simplices on polytopes. *J. Comb. Theory, Ser. A* **96**, 288–302 (2001)
22. Favati, P., Tardella, F.: Convexity in nonlinear integer programming. *Ric. Oper.* **53**, 3–44 (1990)
23. Todd, M.J.: *Computation of Fixed Points and Applications*. Springer, Berlin (1976)
24. Fujishige, S.: *Submodular Functions and Optimization*, 2nd edn. Elsevier, Amsterdam (2005)
25. Murota, K.: *Discrete Convex Analysis*. SIAM, Philadelphia (2003)
26. Iimura, T., Murota, K., Tamura, A.: Discrete fixed point theorem reconsidered. *J. Math. Econ.* **41**, 1030–1036 (2005)
27. Kelso, A.S., Crawford, V.P.: Job matching coalition formation and gross substitutes. *Econometrica* **50**, 1483–1504 (1982)
28. Fudenberg, D., Tirole, J.: *Game Theory*. The MIT Press, Boston (1991)
29. Scarf, H.: The allocation of resources in the presence of indivisibilities. *J. Econ. Perspect.* **4**, 111–128 (1994)
30. Gul, F., Stacchetti, E.: Walrasian equilibrium with gross substitutes. *J. Econ. Theory* **87**, 95–124 (1999)
31. Sun, N., Yang, Z.: Equilibria and indivisibilities: gross substitutes and complements. *Econometrica* **74**, 1385–1402 (2006)
32. Danilov, V., Koshevoy, G.: Existence theorem of zero point in a discrete case. Preprint (2004)
33. Yang, Z.: Discrete fixed point analysis and its applications. FBA Working Paper No. 210, Yokohama National University, Yokohama (2004)
34. Yang, Z.: On the solutions of discrete nonlinear complementarity and related problems. *Math. Oper. Res.* **33**, 976–990 (2008)
35. van der Laan, G., Talman, A.J.J., Yang, Z.: Solving discrete zero point problems. *Math. Program.* **108**, 127–134 (2006)
36. van der Laan, G., Talman, A.J.J., Yang, Z.: A vector labeling method for solving discrete zero point and complementarity problems. *SIAM J. Optim.* **18**, 290–308 (2007)
37. van der Laan, G., Talman, A.J.J., Yang, Z.: Computing integral solutions of complementarity problems. *Discrete Optim.* **43**, 315–321 (2007)
38. Talman, A.J.J., Yang, Z.: A discrete multivariate mean value theorem with applications. *Eur. J. Oper. Res.* **192**, 374–381 (2009)
39. Vives, X.: Nash equilibrium with strategic complementarities. *J. Math. Econ.* **19**, 305–321 (1990)