

## VU Research Portal

### **Decision support tools for urban contingency policy: a scenario approach to risk management of the Vesuvio area in Naples, Italy**

Torrieri, Francesca; Concilio, Grazia

2001

#### **document version**

Publisher's PDF, also known as Version of record

[Link to publication in VU Research Portal](#)

#### **citation for published version (APA)**

Torrieri, F., & Concilio, G. (2001). *Decision support tools for urban contingency policy: a scenario approach to risk management of the Vesuvio area in Naples, Italy*. (Research Memorandum; No. 2001-42). Faculty of Economics and Business Administration, Vrije Universiteit Amsterdam.

#### **General rights**

Copyright and moral rights for the publications made accessible in the public portal are retained by the authors and/or other copyright owners and it is a condition of accessing publications that users recognise and abide by the legal requirements associated with these rights.

- Users may download and print one copy of any publication from the public portal for the purpose of private study or research.
- You may not further distribute the material or use it for any profit-making activity or commercial gain
- You may freely distribute the URL identifying the publication in the public portal

#### **Take down policy**

If you believe that this document breaches copyright please contact us providing details, and we will remove access to the work immediately and investigate your claim.

#### **E-mail address:**

[vuresearchportal.ub@vu.nl](mailto:vuresearchportal.ub@vu.nl)

## SERIE RESEARCH MEMORANDA

Decision support tools for urban contingency policy

Francesca Torrieri  
Crazia Concilio  
Peter Nijkamp

Research Memorandum 2001 - 42

December 200 1

0112001-42



# DECISION SUPPORT TOOLS FOR URBAN CONTINGENCY POLICY

A scenario approach to risk management of the Vesuvio area in Naples, Italy

**Francesca Torrieri**

Dipartimento di Conservazione dei Beni Architettonici ed Ambientali, Università degli Studi di Napoli "Federico 11", Napoli

**Grazia Concilio**

Dipartimento di Architettura ed Urbanistica, Politecnico di Bari

**Peter Nijkamp**

Department of Spatial Economics, Free University, Amsterdam

## Abstract

Contingency management, in particular the management of unanticipated events outside the **control** of an ordinary planning system, has in the last 50 years become an important and frequently debated issue in the **scientific** literature on complex systems management under risk conditions. The urban system **can** be regarded as **such** an open complex system **where** external events, not always foreseeable with a **closed** system's model, **may** strongly impact on the internal **dynamics** of an urban area.

Conventionally, planning the future presupposes collecting information and analyzing it rationally in order to **control** for unexpected contingency events. But it is an important question in the field of urban planning, **how** proper strategies **can** be developed to deal with external uncertainty and shocks that transcend the imagination of policy-makers. **How** should decision-makers respond to **such** unforeseen jumps in a system?

The aim of this paper is to present and apply a new **scientific** decision support method based on the future studies literature, with the aim to help decision-makers in the **strategic** management of uncertainty and risk in order "*to anticipate the extraordinary events correctly in order to act more effectively*" (Godet, 1987). In particular, we will deploy here the scenario methodology in combination with multicriteria analysis and **fuzzy** set theory, as a **useful** learning tool for the governance of complex **dynamic** systems.

In current **debates** on policy-makers' possible reactions to uncertainty (e.g., in the context of sustainability strategies), **very often** the so-called "no-regret" **principle** is **advocated**. The validity of this approach is tested, in the context of the present paper, on **real-world** threats in the Vesuvio volcanic area in the vicinity of the densely populated city of Naples, Italy. Four different policy **scenarios** will be developed with the purpose to examine, **control** and **reduce** the risk for the people concerned in case of a future volcanic eruption and to **lay**, at the same **time**, the foundation for a **drastic** rehabilitation of the entire metropolitan area.

## 1 Introduction

Planning is closely connected with future thinking, as it **constitutes** one of the main tools through which societies **can** express their **freedom** in changing the future. By planning future actions, authorities take decisions which influence and shape **aspects** of the future, **often** with long-term **effects**. In our modern world investigating a range of different possible **futures** and preparing for them, has become a critical challenge in policy **making**. Clearly, **any** decision on an unknown future **needs** an operational approach in order to forecast or map **out** elements of the future. What planners usually do in their **practice** is to forecast the future by extrapolating **from** existing trends. But in the planning environment forecasting is fraught with **many** difficulties, as **often** policy **objectives** are **fuzzy** and the criteria for evaluating consequences unclear. **When** planning under high risk conditions, the necessity to exercise future-oriented feasibility studies becomes more and more relevant, and the **main** task of future studies is then concerned with risk management of unanticipated events. For society it is **often** not possible to prevent hazards, but one **can reduce** risk by developing proper risk strategies which **may also mean** a reduction of **human** exposure to risk. This is especially true **when** dealing with seismic and volcanic risk. In **fact**, **when** it **comes** to large-scale natural disasters **such** as volcanic eruptions, individuals and society are **often** not **well** prepared for risk management. Most responses are short-term in **nature**, **when** these events occur, in part because they occur so infrequently that we simply fail to maintain our **vigilance**. **How much** risk is society willing to accept? **How much** is it willing to **pay** to **reduce** the risks **from** natural hazards? These questions have not been carefully addressed in **many** planning situations, but ought to be addressed in **strategic** future studies and future scenario evaluations. (see Eduljee 2000)

These observations are highly relevant in the case of the Vesuvio area near **Naples**, Italy, **where** approximately one million people are living under high risk conditions as a **consequence** of the **fact** that the probability of a volcanic eruption is gradually increasing, **caused** by seismic and geological **changes** in the area concerned. Under **such** conditions the use of **scenarios** in combination with proper decision support tools is an indispensable tool for assisting policy-makers in complex planning strategies based on no-regret **principles**.

This paper aims to present (i) **backgrounds** on risk management in a metropolitan context (taking the Vesuvio area as a case of reference), (ii) evaluation and scenario tools for **strategic** risk decisions, and (iii) various case study results on risk and rehabilitation options in the Vesuvio area. In the next **section** we **will** offer a concise review of **futures** research methods.

## 2 Decision-making and uncertainty: future-visioning methods

Since the 1960's **futures** research has become a new scientific endeavor which originated mainly in the military area. In the history of future studies we **may** distinguish various approaches which aim to offer a **scientific** underpinning for the analysis of **future** events (blueprint thinking, normative thinking, nested thinking, scenario thinking, evolutionary thinking, learning thinking etc.).

It has increasingly been recognized that **systematic** future research is a **useful** tool to develop procedures and strategies for a better management of future uncertainty. Lessons learned from **such** studies concerned in particular the **recognition** of the need for more qualitative and **strategic** types of analysis and the **fact** that the future is not a linear extrapolation of the past and the present.

According to Dewulf (1991) we **can** distinguish between four **main** classes of future research: forecasting, exploratory research, speculation, and projection. Forecasting and projection are mainly used to **clarify** the future situation, while exploratory research and speculation **may** be used to **generate** new ideas or opinions in situations of a high uncertainty (Dewulf, 1991). Quantitative analysis methods are most suitable to **well** known or frequently occurring

situations. In the context of the present paper we will focus our attention on scenario thinking as a tool to forecast and explore the future.

Scenarios are essentially consistent and feasible mappings of the future (see Vleugel 2000). They may be seen as exogenous developments to which decision-makers may respond. In a game-theoretic perspective, scenario analysis is essentially the study of **strategic** behaviour of actors as a response to the occurrence of other, unforeseen or unpredictable, actions. It plays a major role in a world of uncertainty, **where** predictability is low and **where** rational policy actions are needed. Against this background, scenario analysis offers a promising contribution to **decision-making** under uncertainty, as it **provides** a framework for generating and digesting information for balanced policy decisions (Nijkamp et. al. 1998; Vleugel 2000).

In the past decades various classes of scenario **building** have been developed. One may distinguish *inter alia*: intuitive **scenarios**, idealistic **scenarios**, qualitative **scenarios**, quantitative **scenarios** and participatory **scenarios**. In **all** cases, **scenarios** are analytical and visionary **mental** constructs. They are not necessarily valid, but offer a frame for thinking in a rational way about the future. Scenario approaches aim to **generate** useful learning insights into a complex **dynamic** system; because of its qualitative **nature**, no formal model (like a mathematical systems model) is used. Kahn and Wiener (1967) **define** a scenario as “an hypothetical sequence of events constructed for the purpose of focusing attention on casual **processes** and decision points”. According to Makridakis and **Wheelwright** (1983, p.651) scenario writing “takes a **well-definite** set of assumptions, then develops an imaginative conception of what the future would be like if the assumption were true”. . .” Scenarios present a number of possible alternatives, **each** one based on certain assumptions and conditions. It is then up to the decision-maker to assess the validity of the assumption in deciding which is most likely to become reality.”

There are **many** strategies to **cope** with uncertainty like: ignore uncertainty, **identify** and **specify** uncertainty, do nothing and let uncertainty be reduced by the **time**, accept uncertainty and act consciously in its presence, or see uncertainty not as a threat, but **rather** as an opportunity to creatively shape the future. In current **debates** on policy-makers’ possible reactions to uncertainty we **also** observe different views (van Geenhuizen et al. 1988, van Geenhuizen and Thissen 2001) **such** as overreaction, loss-aversion, **mental** record, or fairness responses.

Nowadays the growing awareness of scarcity of **human** and natural resources and the consequent need to avoid misallocation due to wrong environmental policy evaluations, has induced a strong interest in the field of long-term thinking, as is *inter alia* witnessed in the **principle** of a *no-regret strategy* as a tool to avoid unnecessary losses. This approach seems **also very** useful in other cases, like **strategic** territorial planning, **where** decision **processes** and actions are characterized by deep uncertainty due to real-world complexity and a fast changing reality, imperfect information on decision alternatives, and the multiplicity of actors involved. **When** an urban decision-maker is **faced** with planning in risk situation, a solid future analysis and evaluation of the **dynamics** of urban settlements is necessary. First of all, this is because the speed of change has increased, and with it the difficulty to **control changes** deriving from external future events against the background of inert **structures** of cities. Moreover, there is increasing understanding that quantitative variables which in the past had clearly **identifiable** trends that could easily be plotted have nowadays a **random** behavior or tendency that **makes** everything more uncertain. In this sense, new approaches in facing risk in case of planning urban settlements have to be developed.

The above challenges **will** be tested, in the context of the present paper, by investigating serious threats in the Vesuvio volcanic area in the vicinity of the densely populated city of **Naples**, Italy. Four different policy **scenarios** will be developed with the purpose (i) to **control** and **reduce** the risk for the population concerned in case of a future volcanic eruption and (ii) to start, at the same **time**, a **drastic** rehabilitation of the entire metropolitan area of **Naples**. A

possible Vesuvio eruption represents in this context not only a threat to be managed in case of emergency, but **also** an opportunity to be exploited. Thus there is a need for contingency strategies. Two planning alternatives will be envisaged here, viz. development of a new settlement structure for the metropolitan area or temporary evacuation and relocation of the population in case of eruption.

The hypothesis of structurally relocating most residents in the Vesuvio area to different settlements of the larger **Naples** metropolitan area is adopted in our study as an alternative to the emergency plan designed by the Civil Protection Agency which aims to temporarily move - during an eruption period - the **whole** Vesuvio population towards northern Italian towns. The idea to move on permanent basis part of the Vesuvio population at risk to other settlements in the **Naples** area has two **main** goals: a risk reduction in case of eruption and a valorization of urban resources that are currently seriously degraded. Looking at the larger **Naples** metropolitan area, this type of intervention **may** represent an opportunity for a significant rehabilitation of the **whole** area. The **Naples** metropolitan area, in **fact**, is continuously growing without exploiting agglomeration **economies** due to the **lack** of a general **cohesive** planning strategy.

In our paper a new methodological approach will be proposed, that aims at carrying out a scenario design experiment supported by integrated evaluation methodologies for the planning of population relocation in the Vesuvio area. In particular, our study will explore how integrated modern evaluation methodologies can support scenario building by incorporating policy evaluation elements regarding **effects** and **preference structures** on planning strategies. Against this background, **Section 3** will provide a brief introduction to modern decision support tools.

### **3 Decision support tools in an uncertain world**

#### **3.1 Methodology**

In dealing with **basic** uncertainty, **such** as in the case of a volcanic eruption, policy-makers face **many** decision **factors**, e.g. unpredictability of events, present political conditions, **inertia** in behavioural responses, system constraints etc. In this context, **econometric** and statistical methods are usually not feasible tools, as they require a lot of hard data that are difficult to **collect**. Actually, contingency management is **often** characterized by incomplete information about the past, partial information about the present and no or unreliable information about the future.

The decision **process** is usually extremely **dynamic** and is not necessarily based on an a priori **well defined** choice structure between distinct possible alternatives, but **can** be interpreted as a **process** of **building** alternative actions **where** the **elements** which determine the actions are in a momentary **condition** of **cognitive** equilibrium (Zeleny, 1994). From this perspective, the **decision-making process** is oriented toward problem structuring and exploring the **action space** for **building** possible solutions. The role of evaluation methods appears **very** interesting in this field, not only in order to support a ranking of choice alternatives, but also to guide decision-makers in **managing** a decision **process** and its results through a **descriptive** or interpretative approach. In a world of uncertainty, traditional evaluation methods (cost-benefit analysis, cost-effectiveness analysis etc.) do not seem to be **very** appropriate from this perspective. Their data requirements are too high and they tend to neglect the ever-changing conditions in a decision environment.

Multicriteria evaluation methods appear to be more appropriate to support the exploration of alternative policy **scenarios**; in **fact**, they are **capable** of dealing with multiple dimensions, soft data, **interactive** strategies, and try to give more attention to **conflicts** arising among various stakeholders involved in the **decision-making process**.

A great variety of multicriteria methods has been developed in the past decades. We will focus our attention here on a particular **class** of qualitative multicriteria methods, viz. Regime analysis. Furthermore, we will explore its validity by introducing a complementary method based on fuzzy **logic**, coined NAIADE. Fuzzy set theory tries to Capture the uncertainty of the information available in the decision-making process by introducing the concept of degree of membership of an element with respect to some given set. Fuzzy or imprecise nominal information is the basis of fuzzy set theory, since it considers **all** the cases **where** is not possible to **define** a **precise** and **objective** measurement system. These methods **will** be deployed in a policy scenario context.

Policy strategies sometimes called policy **scenarios**, can be constructed in various ways. The design of a policy strategy consists of a series of phases, which **can**, at least in theory, be presented as a circle. (see Figure 1). In **practice**, designing policy strategies is an **interactive** process in which ideas and plans move back and forth between interrelated activities. Cyclical **processes** are used with the aim to adjust the decision-making process, therefore orienting the policy strategies more and more towards actions. Decision-makers should **learn** during the process to make better estimates of the **effects** of a decision, to adjust the policy **objectives** **after** experiences, to assess the **effects** of past decisions, and finally to get more routine in complex decision-making.

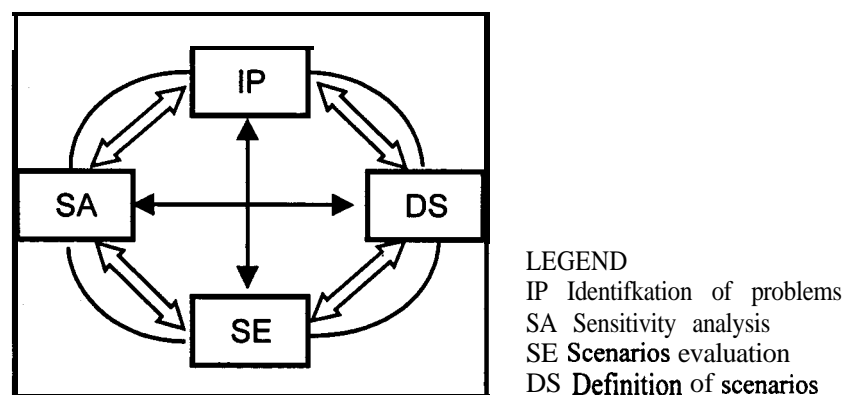

Figure 1 The cyclical evaluation process of policy strategies

### 3.2 A combinatorial approach

On the basis of the approach described in the last section a combinatorial approach (see Figure 2) is proposed according to the cycle-wise process described in Figure 1. The goal of **all** elements, events, assumptions, actions and impacts which **contribute** to the policy scenario **building** process is not to identify a **final** and one-shot **action**, but to **create** a learning and **dynamic** tool during the entire decision process.

At this stage we **will** integrate during the phases of the policy scenario development process various elements from decision theory; in particular, we will focus our attention on both **descriptive** and **prescriptive** decision theory. The **descriptive** approach is more oriented to the phase of problem structuring in the field of multi-actor decision **processes**, **aiming** at studying interests, reactions, issues, problems, opportunities, threats and structural **changes** of a complex reality, through the creation of an **interactive** dialogue with **all** parts involved, while the **prescriptive** decision theory is more concerned with the choice issue itself. The description and evaluation of the elements that become driving **forces** to the **scenarios building** process guide decision-makers in understanding **all** possible implication of future **action** plans.

In a context of **interactive**, participatory or **communicative** modes of decision-making the use of a so-called Forum Group and interviews with the public appears to offer a useful decision aid in order to acquire the **basic knowledge** **from** stakeholders and experts through discussion

and exploration of **all** relevant viewpoints on the issues under analysis. In particular, **semi-structured** interviews aim at gathering proper knowledge on a **specific** issue; in fact, they are characterized by the exploration of broad and **superficial** knowledge as **well** as the collection of **specific** and in depth knowledge, for example, through the use and implementation of flexible, but **focussed** questionnaires.

**After** the knowledge acquisition **process**, a strength-weakness-opportunities-threats (SWOT) analysis **can** be carried **out** in this context in order to **identify** the relevant **forces** that **may** have a (**positive** or negative) impact on the phenomenon in question.

It seems logical to use a SWOT analysis as the starting point for the evaluation of the policy scenarios or strategies to be designed. In our study, the scenario evaluation is carried **out** with the help of multicriteria methods. We **will** deploy here two classes of multicriteria analysis, based on a different **logic**, viz. the NAJADE (**fuzzy set**) method and the Regime (pairwise comparison) analysis.

The NAJADE (**Novel Approach to Imprecise Assessment and Decision Environment**) (see Munda 1995) is a discrete multicriteria method which is able to include crisp, stochastic or **fuzzy** measurements of the performance of a choice alternative with respect to a relevant evaluation criterion. Using a pair-wise comparison technique, NAJADE generates a ranking of alternatives. It allows for two types of evaluation. The **first** possibility is based on the score values assigned to the criteria of **each** alternative and is then performed using an impact matrix. The **second** kind of evaluation, which appears to be **very** useful in our context, analyzes **conflicts** among different interest groups and the possible formation of a coalition in **regard** to the proposed policy scenarios, using an equity matrix, based on a linguistic evaluation of alternatives by **each** group.

The Regime analysis (see for details Nijkamp et al. 1991) is used in this context to check the robustness of the results obtained by trying to carry **out** a sensitivity analysis on qualitative performance scores and policy weights attributed to relevant choice criteria. The fundamental framework of this multicriteria method is based **upon** two standard kinds of data: an evaluation (assessment, effect or impact) matrix and a set of political weights (preferences, priorities). The evaluation matrix is **composed** of elements that measure the **effects** of **each** alternative considered in relation to **each** relevant choice or policy criterion. The measurement of these **effects can** be expressed in a qualitative or quantitative way. The set of weights **provides** information about the relative **importance** of the criterion to be considered.

Our methodology is thus based on a blend of these two evaluation techniques. Figure 2 shows the combinatorial approach deployed in our analysis. It is based on 4 **main** activities:

1. Identification of problems
2. **Definition** of policy scenarios
3. Evaluation of policy scenarios
4. Sensitivity analysis.

In these **successive** steps the analytical **tools** described in this **section** are used to **reach** the **specific objectives** under consideration. In the next **section** we **will** describe the policy question to be studied in our paper, viz. the development of **strategic** tools to manage the Vesuvio risk in the **framework** of the larger **Naples** metropolitan area.

#### **4 Case study: the Vesuvio area**

Volcanoes belong to the natural physical geography of our earth. They **can** be found in **all continents**, although they are not uniformly distributed. In the European territory some hundred volcanoes have shown eruptions in the past ten thousand years, sometimes with a limited effect, but sometimes also with unprecedented damage to the wider surroundings. Volcanoes present serious risks, in terms of fatal consequences for nearby densely populated **areas** (**such as Naples** near the Vesuvio) and of severe ecological damage to natural habitats. Any significant eruption normally **causes** a serious disruption of man-made and natural



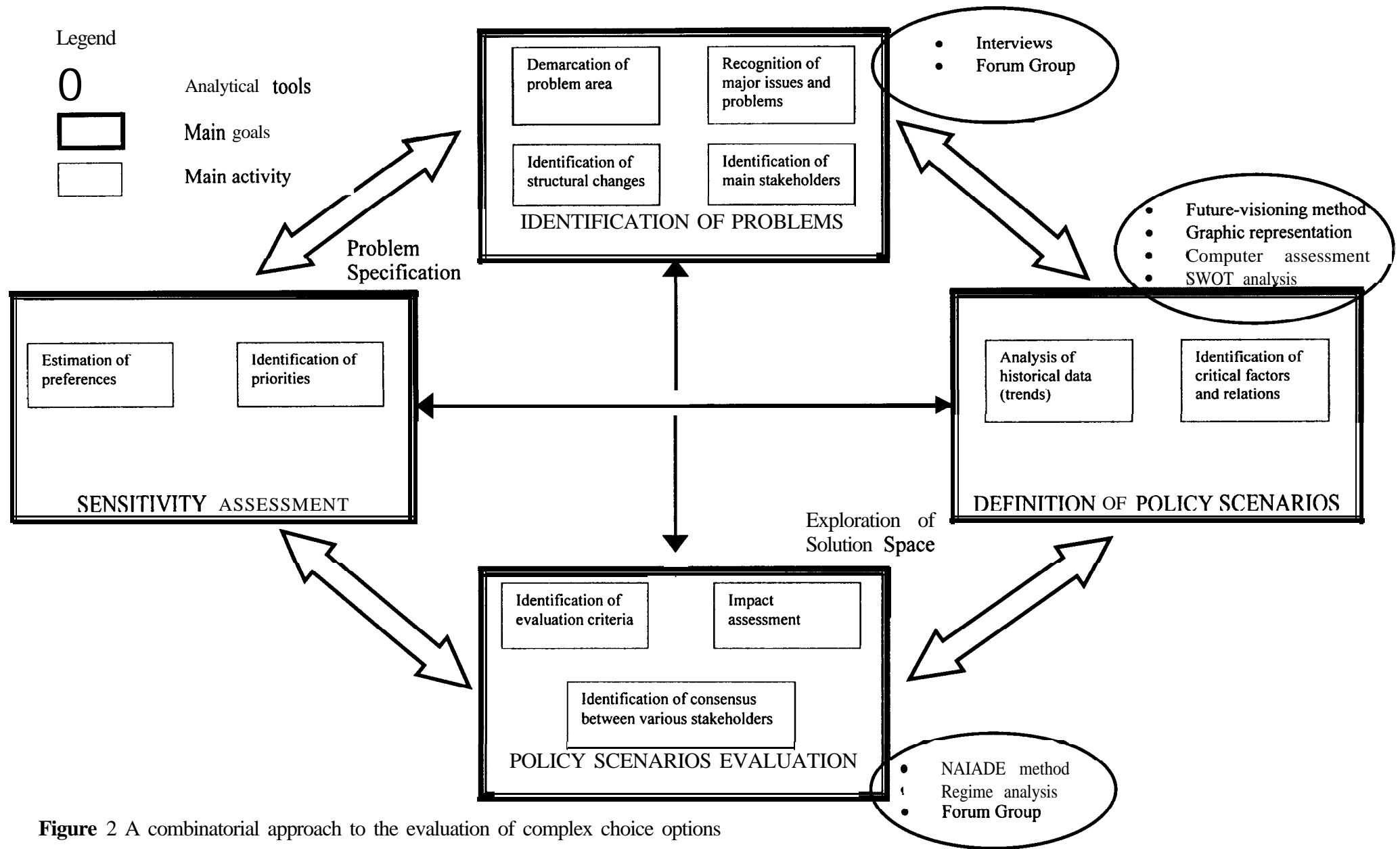

**Figure 2** A combinatorial approach to the evaluation of complex choice options

environments. Admittedly, volcanic eruptions **may also** trigger positive developments. For example, it is well-known that the ancient Romans used volcanic ash, so-called pozzolan, as solid construction material. Without pozzolan immortal buildings **such as** the Pantheon would never have been constructed and survived over the centuries. In recent years we have witnessed an increasing attention for seismic investigations (e.g. geochemical studies of fluid emissions) in order to **identify** and recognize pre-eruptive seismic signs and **shifts** of magma, as **well as changes** in the level of volcanic activity. The development of monitoring and early warning systems is a natural complement to this expanding field of research. The groundwork of scientific research into volcanic eruptions rests evidently in the natural sciences, but the study of the **social**, ecological, **economic**, geographic and transportation implications **finds** its roots in the broader field of the **social sciences**. Why is the study of volcanic eruptions different from the analysis of other unexpected events? First, the probability of an eruption (**when, where**) is **very hard** to estimate or to **predict**, so that volcanic impact assessment is fraught with **many** uncertainties. In the **second place**, the consequences of a volcanic eruption **may be** far reaching and in most cases irreversible (in terms of loss of **human life**, destruction of houses and **infrastructure** etc.). And **finally**, for **many** reasons people have in the course of history **often** tended to settle in the vicinity of volcanic **areas** without due **regard** of the risks involved. In case of densely populated volcano **areas** it **will be** a **difficult** task for policy to undertake preventive measures e.g. by encouraging a spatial displacement of **human** activity. The approach proposed in the previous **section** **will be** applied to a **real** word-case concerned with the Vesuvio area near **Naples**. The **rather** realistic threat of a Vesuvio eruption in the next decades has induced a **process** of policy concern, leading **inter alia** to plans for on a **drastic** rehabilitation of a large area in the Campania Region. Based on *no-regret* **principles**, the **main** idea is to develop a contingency strategy for the area at risk in combination with a wide-scale improvement of the quality of life in the metropolitan area. The integration of different policy-analytical methods **can** support decision-makers in this complex **decision-making** **process** by developing a **scientific** framework involving problem structuring, designing alternatives, evaluation, and selection of choice options.

#### 4.1 The territorial context

Our study concerns the entire metropolitan area of **Naples**, located in the Italian Campania Region and **focuses** its attention on the municipalities that are in the vicinity of the Vesuvio volcanic area. These municipalities have been declared in the Civil Protection as strong risk **areas** in case of a Vesuvio eruption. The entire area has been divided into two different zones: a "*red zone*" and a "*yellow zone*" according to the level of risk. In particular, the "*red zone*" is the one with a high probability to be severely damaged by a possible eruption. This area (about 250 km<sup>2</sup>) includes 18 municipalities with a total population of about 350.000 inhabitants. During the last explosive eruption (1631) **almost** 20% of the area was destroyed by the piroclastic **flows**. According to various volcanic experts the current geological **condition** of the Vesuvio volcano **may generate** an eruptive event (in the next 30 to 50 years) that is likely extremely explosive and similar to the one that happened in 1631. Different interpretations of past eruptions of the Vesuvio have led other volcanic experts to forecast less explosive eruptions, but with an **higher** probability in the nearby future.

The area at risk is mainly located along the **coast**. This area has an extraordinary natural beauty, **complemented** with high **architectural** and historical values of the characteristic vesuvian **villas** (from the seventeenth century) and the archeological sites of **Pompei** and Ercolano. The **economy** in this area is essentially based on the third sector, and comprises mainly activities linked to the sea like **coral** carving, shipyards, restoration, antique trading, retail trade and other small **scale handicraft**. The **agriculture** is still based on the production of typical local **products** (e.g., biological apricots); in particular, the floriculture **accounts** for approx. 35% of the total production of the **province** of **Naples**.

Uncontrolled urban development has led in the last 50 years to a **condition** of serious degradation of the area under analysis, characterized by **very high density**, low living conditions, unemployment and criminality.

## 4.2 Issues and goals

The territorial development of urban sprawl, caused by an uncontrolled planning of the coastal area, has led to a loss of the indigenous feature of the area under consideration. Moreover, the low quality of life reinforced by the **lack** of green **areas** inside the urban area, the high level of air pollution caused by congestion and **traffic**, and the **lack** of public services, have stimulated the original population to abandon those municipalities.

The data obtained in the **framework** of our study on the willingness to move by inhabitants of the area under investigation, show that the natural trend to abandon the area for moving elsewhere is equal to 50.5% in the coastal zone area in contrast to 2.3% in the area located nearby the Vesuvio **slopes**. The risk does not seem to represent the only problem for this area; **also a drastic** rehabilitation seems to be necessary. Consequently the **main** challenges for the urban planning in this area are:

- reduction of population density in the area at risk;
- **drastic** rehabilitation and requalification of the area concerned;
- improvement of the local quality of life;
- conservation of natural, historical and archeological sites.

Our study **will** explore in particular the possibility to relocate part of the population living in the risk zone in the metropolitan area of **Naples**. Against this background, the risk **may** be seen as an opportunity to start a **drastic** rehabilitation of the entire metropolitan area of **Naples**.

## 5 Identification of problems

### 5.1 The Forum Group approach

As a part of an **interactive**, participatory and **communicative** approach to risk and land use management of the Vesuvio area, a so-called Forum Group was established, involving experts from various **disciplines** such as: urban planning, transportation planning and geophysics and seismology. The **main** issues in an intensive long-lasting brainstorm activity were to **define** an approximate number of people to be relocated to other settlements and to **identify** possible **areas** for there new settlements. **After** intensive consultation some agreement was reached on the above issues.

First, the approximate number of people to be relocated in a feasible way is about 350.000 (this number corresponds largely to the entire populations of the **red zone**). **Second**, there is a consensus on the choice of the area **where** to **locate** people in terms of environmental, infrastructural and territorial conditions. And **finally**, a list was established of the **main** stakeholders to be involved in future urban rehabilitation **projects** such as the Environmental Association, the National Park of Vesuvio, the Entrepreneurs' Associations and the **Province** of **Naples**.

### 5.2 Information on the future by means of interviews

Besides the Forum Group information, also semi-structured interviews were held to **identify** possibilities and barriers of new territorial policy for the area concerned. Particular attention was given to possible events, policy goals, risks, fears, etc. **All** these ingredients were used as an input for the policy **scenarios**. **Many** representatives **from** the surrounding municipalities were interviewed on various **aspects**, such as technical, territorial, socio-economie,

infrastructural and legal elements of the policy plans. In particular, the interviews addressed the following questions:

- *Risk conditions of the Vesuvio area*
  - Opportunities of a re-settlement policy
  - Viability of a mobilization strategy
- *Rehabilitation of the metropolitan area of Naples*
  - Settlement conditions
  - Action planning
- *New possibilities for the metropolitan area of Naples*
  - Barriers and conditions
  - Risks and creative solutions
- *Relocation strategies*
  - Resources and goals
  - Indirect issues (e.g., public facilities)

The knowledge collected through the interviews shows that the attitude to long-term thinking varies in accordance with realistic future projections (see Figure 3).

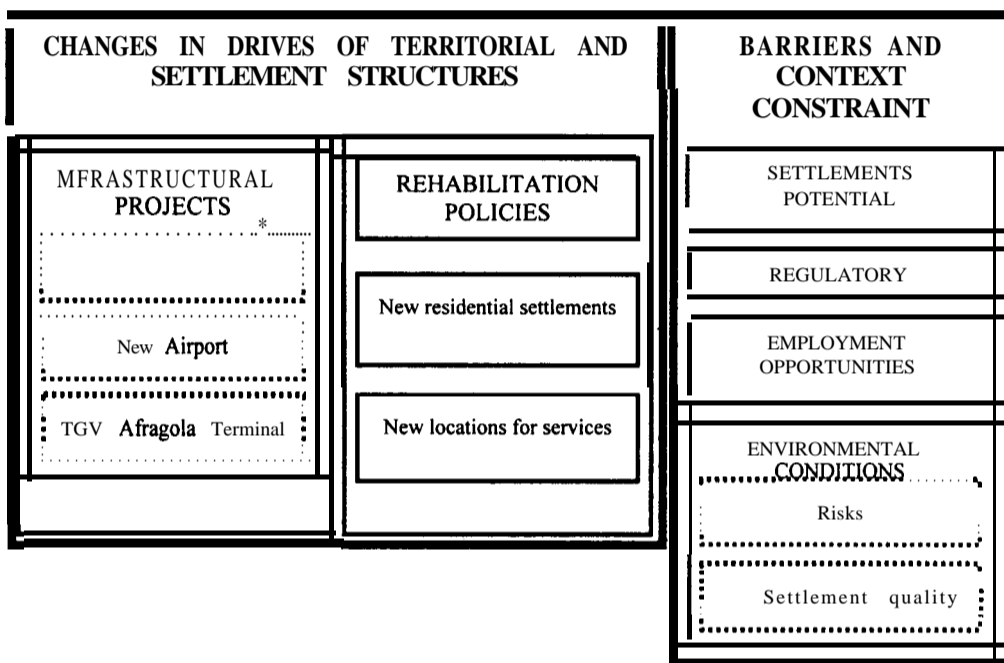

Figure 3 Structure of the elements to imagine the future

## 6 Four policy scenarios for the Vesuvio area

In this section we will describe the design and content of four relevant policy scenarios for the area.

### 6.1 Terms of reference for the policy scenarios

#### Scenario type

The scenarios are forward-looking and are written to support specific policy decisions. Forward-looking scenarios start from the present, indicate which events might happen in case of alternative developments and, finally, describe possible future outcomes. They may be relevant for decision-makers in defining proper planning strategies for the metropolitan area of Naples.

### *Time horizon*

The time horizon to develop meaningful policy scenarios has been set for a period of 20 years which is consistent with the prediction of a likely future eruption and the time needed to start a reconstruction of the entire area.

### *Municipalities selected*

The municipalities have been selected integrating the territorial plan proposed by the Province of Naples and the proposal by the Vesuvio research team. A total of 29 municipalities has been selected as possible candidates for relocation. (see Figure.4)

### *Scenario features*

The level of complexity of the policy questions is reduced by dealing only with two types of features: viz. (i) structural descriptor and (ii) instrumental descriptors.

The structural descriptors represent recurrent land use and economic themes in the interviews and have been used to determine the basic structures of the scenarios (Table 1).

<b>Relocation distribution</b>	<b>Economic structure of the Vesuvio area</b>
<ul style="list-style-type: none"><li>• Diffuse relocation</li><li>• Clustered relocation</li></ul>	<ul style="list-style-type: none"><li>• Conservation of the existing economic structure</li><li>• Economic conversion towards cultural/tourist activity</li></ul>

**Table 1** Structural descriptors of scenarios

Instrumental descriptors represent the main concerns revealed by the interviews that are considered relevant for the scenario specification. (Table 2) We will now briefly describe the four options from Table 1

<b>Concerns</b>	<b>Theme</b>
<b>Economy</b>	Minimize relocation costs Creation of new employment Economic development
<b>Society</b>	Improving quality of life Integrate different communities Reduce risk Avoid inert behaviour
<b>Environment</b>	Improve environmental quality and standard of living Preserve historical and architectural values
<b>Land use</b>	More efficient use of space Settlement potential Territorial balance Compatibility with existing projects
<b>Traffic and transport</b>	Concentrate new location near existing public transport terminals Improve public transport Exploit modal shift potential Reduce spatial mobility

**Table 2** Instrumental descriptors for scenarios

### **Diffuse relocation**

According to this hypothesis all 29 municipalities selected will share the burden of the relocation policy and the plan to start a restructuring process.

### **Clustered relocation**

This assumption implies that only 11 municipalities will be affected by the relocation policy. These represent altogether three territorial poles and will be clustered according to the following criteria (see Figure.5) :

- Location of the new **airport** of Grazzanise
- Location of the new TGV **Afragola** railway station
- Environmentally **attractive** elements
- Vicinity to major railway stations.

**Conservation of the existing economic structure**

In this plans the future **economic** structure is supposed to have the same characteristics as those reported in the last census available (199 1): the structure and share of the population working in different **economic** sectors **would** not change. As regards the **economic** sectors, we have used the data on 17 employment categories reported in the census of 199 1 (ISTAT).

**Economic conversion towards cultural/tourist activity**

The future **economic** structure **will** in this model be reorganized in accordance with a **considerable economic/tourist** development of the Vesuvio area. This assumption imagines that the Vesuvio area **will** be completely reoriented towards focused activities for enhancing tourist activities. In this case we assume that the population **will** mainly be redistributed over 8 out of the 17 employment categories mentioned above. The **scenarios** have been developed by varying inter alia future trends of the population as of the year 2000. The analysis of the data has been conducted on the basis of **time** series of the population census (1961, 197 1, 198 1, 199 1 and 2000, available at the ISTAT).

Figure 4 29 municipalities selected

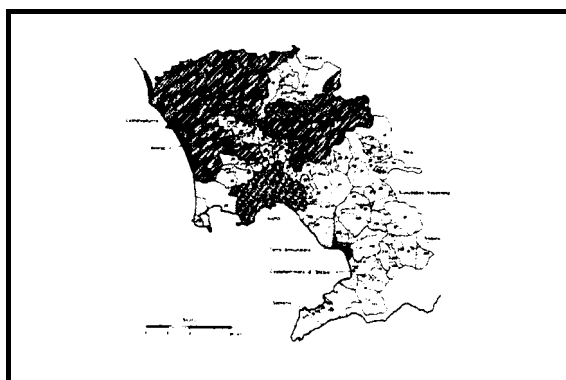

 Municipalities selected

Figure 5 Cluster of municipalities

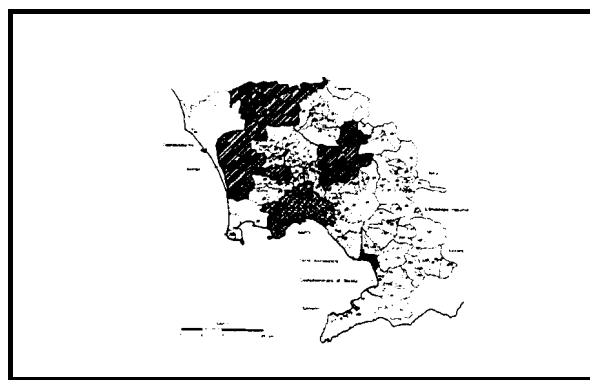

 Cluster of municipalities

		RELOCATION REDISTRIBUTION	
		Deconcentrated	Tri-polar
ECONOMIC STRUCTURE	Current economic structure	Scenario 1a	Scenario 2a
	Tourist development	Scenario 1b	Scenario 2b

Table 3 Design framework of the scenarios

### *Scenarios*

The above mentioned assumptions have formed the ingredient for the definition and specification four policy scenarios.

#### **Scenario 1a**

In this scenario we envisage the distribution of 350.000 inhabitants of the “*red zone*” towards all 29 municipalities selected (see Table 2). The migration flow from the Vesuvio area is then proportionally re-distributed to the foreseen population up to year 2020. The spread over these communities aims at reducing the problem of integration with the existing population. The future economic structure will maintain largely the same characteristics as the one reported in the last census (1991). This assumption is in line with the industrialists’ associations to improve and promote local activities, without altering the equilibrium among the existing firms. From the perspective of the internal mobility of people in the metropolitan area of Naples, this scenario does not aim at changing the current modal split. Moreover, since most of the selected municipalities are located along major railway lines, it seems plausible that there is also an improvement in the use of public transport.

#### **Scenario 1b**

In this scenario we imagine to distribute the 350.000 inhabitants of the “*red zone*” over all 29 municipalities like in scenario 1a. The migration flow from the Vesuvio area will again be re-distributed proportionally according to the foreseen population in 2020. In this case however, the economic structure will be altered, because of a strong economic and tourist development in the Vesuvio area. The Vesuvio area in fact, has an abundance of beautiful natural, historical and archeological sites and resources. This assumption is in line with the idea to re-orient all planning and research activities so as to improve the tourist attractions of the Vesuvio area. It is even possible to imagine that this area would become a big cultural/natural park where only a few people will live. All people could then be employed in cultural and tourist sectors that may arise in the existing cultural-historical part of this region and live somewhere else. Also in this scenario the mobility of people and accessibility to amenities can be guaranteed by the vicinity of the municipalities to main railway stations. The labour force is expected to move from its place of origin, but to continue to be present in the Vesuvio region, without losing jobs.

#### **Scenario 2a**

In this scenario we assume to concentrate the population of the Vesuvio area in three territorial poles, so that only 11 out of the 29 municipalities will be affected by the relocation policy and by the restructuring strategies (see Figure 5). The distribution of the population in these 11 municipalities will follow the natural growth trend of the current residential communities, considering a time horizon of 20 years. A concentration of the population in a few population centers may help to avoid the loss of identity for the communities concerned. The economic structure of these municipalities will then maintain the same characteristics as those reported in the last census (1991). The idea to concentrate and improve local activities is consistent with the strategic planning views of industrialists’ associations aiming at preserving traditional and local features in the economic sector and reducing the transaction costs. Moreover, in this scenario the accessibility in the Caserta basin is assumed to improve by reducing the current mobility in the Naples region.

#### **Scenario 2b**

This scenario takes for granted that the population in the Vesuvio area will be distributed over 11 municipalities reported in Figure 5. In this case we envisage again an increase in tourist activity according to the tourist development of the Vesuvian area. This assumption tries to comply with environmental constraints, in particular to reduce the use of land and to preserve natural ecosystems and historical sites. The plan to invest in the tourist sector can also make these areas more attractive for the relocalized population, offering them a better quality of life

and more favorable environmental conditions. Also in this scenario, the location of the new regional airport and the railway station of the high-speed train can facilitate the growth of new firms and services and offer an easy access for tourists. The link with the native place, due to the tourist development and the concentration of population, may reduce the problem of loss of local identity.

### 7 A SWOT analysis of the scenarios

The four scenarios described in section 6 will be now systematically be evaluate by using a SWOT analysis and some multicriteria methods, respectively.

The SWOT analysis is carried out with the aim to highlight critical points in envisaging the scenarios, by trying to take advantage of strengths and opportunities and to minimize weaknesses and threats in the design of policy strategies. (Figure 6)

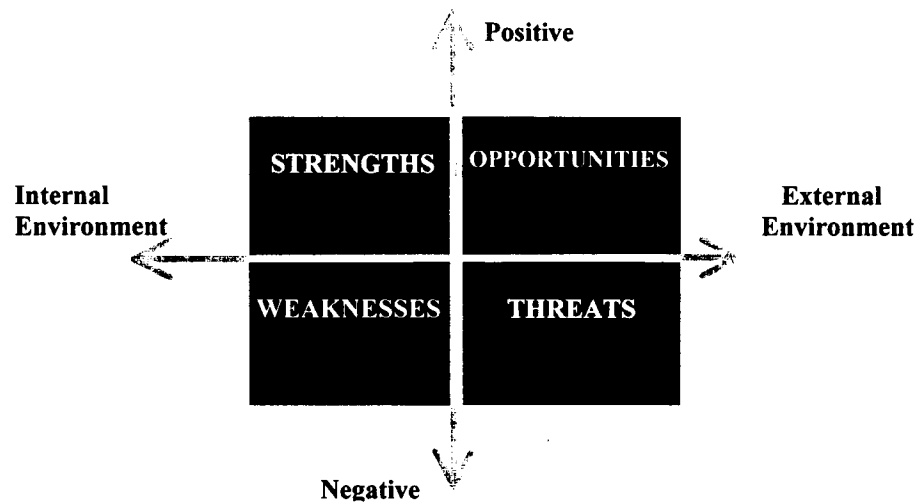

**Figure 6** The SWOT analysis framework

In this context each site-specific scenario is considered as belonging to the internal policy environment, while the development of the entire metropolitan area of Naples represents the external environment. To identify the elements of the SWOT analysis the following questions are raised: (see Table 4)

STRENGTHS	OPPORTUNITIES
<ul style="list-style-type: none"> <li>• Which are the advantages?</li> <li>• What can the internal environment offer according to the relevant assumptions ?</li> </ul>	<ul style="list-style-type: none"> <li>• Which are new future chances (in the technological field, in the market, from a social viewpoint) in regard to policy actions?</li> <li>• Which are the positive processes triggered by the scenario perspective ?</li> </ul>
WEAKNESSES	THREATS
<ul style="list-style-type: none"> <li>• Which are feasible factors?</li> <li>• Which needs of the future on the internal environment cannot be coped with?</li> <li>• Which consequences should be avoided?</li> </ul>	<ul style="list-style-type: none"> <li>• Which are obstacles to be overcome?</li> <li>• Which are undesirable implications that may be triggered off and so should be controlled?</li> </ul>

**Table 4** Ingredients of SWOT analysis



Table 5 provides a summary of the SWOT analysis for each scenario. The scenarios will be used in interpreting the scenario results (see section 8)

## 8 Scenario evaluation

### 8.1 Choice criteria and impact matrix

According to the elements included in the SWOT analysis (which represent crucial points for the future planning of the area in question) a set of judgement criteria has to be specified. The definition of judgement criteria to assess the impacts of the four scenarios follows a hierarchical structure considering two main stages in the criteria (aggregate criteria and specific criteria). The first class is rather general and reflects the objectives of sustainable urban and territorial development (as advocated inter alia in Habitat II and Local Agenda 21), aiming to reach a blend of economic efficiency, a social justice and the conservation of natural and cultural resources. Three elements of the aggregate criteria are considered:

- Economic efficiency and compatibility;
- Conservation and valorization of local features, environment and culture;
- Social and intergenerational equity.

For each of the above mentioned three classes a set of specific criteria has been selected according to the critical elements identified through the SWOT analysis. Figure 7 represents the hierarchical structure of the criteria.

		SCENARIOS			
		1a	1b	2a	2b
STRENGTHS	Improve and consolidate the economic structure without altering existing equilibrium	Creation of new employment in the tourist sector	Improve and consolidate the economic structure	Creation of new spatial economic poles	
	Consistency with the territorial, environmental and urban hierarchy	Consistency with the territorial, environmental and urban hierarchy	Spatial aggregation	Low costs (infrastructures, incentives, settlements)	
	Integration with local communities	Consistency with the actual trend of growing population	Maintenance of cultural roots of relocated community	Spatial aggregation	
WEAKNESSES	High costs (settling, incentives, infrastructure)	High costs (settling, infrastructure)	Variation of demand and supply	Variation of demand and supply	
	Congestion	Congestion	Alteration of territorial hierarchy	Alteration of territorial hierarchy	
	Loss of cultural identity of Vesuvio community		Changes in social stratification	Changes in social stratification	
OPPORTUNITIES	Consistency with territorial plan	Creation of new markets	Location of big infrastructure	Creation of new market	
	Spread of environmental and urban rehabilitation	Valorization of natural and architectural heritage	Creation of new community	Co-financing by private and public stakeholders	
	Renewal of social structure	Renewal of social structure		Location of big infrastructure	
TH	Lack of strong attraction points	Lack of tourist demand	Administrative and bureaucratic constraints	Administrative and bureaucratic constraints	

Social inequity	Environmental degradation	Creation of ghettos	Creation of ghettos
	Social inequity		

**Table 5** Summary table of SWOT analysis

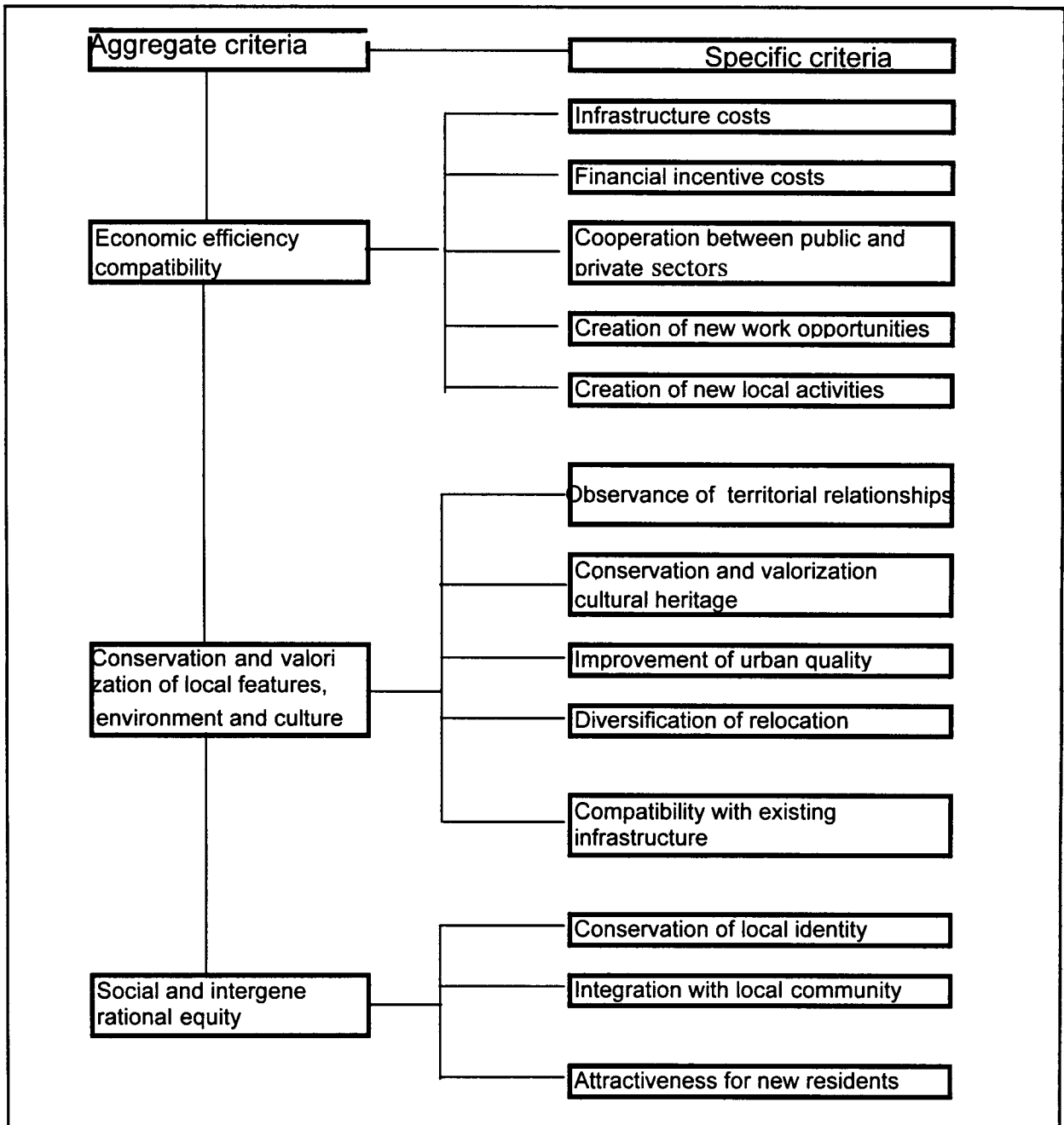

**Figure 7** Hierarchical structure of evaluation criteria

Starting from the above structure of criteria and assessing all impacts associated with the four above defined scenarios, the following qualitative (categorical) impact matrix was constructed. (see Table 6).

The impact related to each criterion has been assessed through a categorical evaluation scale based on the nine-point scale proposed in the NAIAD method (Munda 1995). This method is

a discrete multicriteria method that allows two types of evaluations: the first is based on the score values assigned to the criteria of each alternative and is performed using an impact matrix; the second one analyses conflicts among the different interest groups and the possible formation of coalitions according to the proposed alternatives, using an equity matrix, based on a linguistic evaluation of alternatives by each group. In this section we will develop the first type of analysis, where each criterion has been defined in respect of the relevant scenario, while in the next section we will carry out the final ranking of the policy scenarios and the social consensus analysis.

For example by looking into the economic criteria, the infrastructure costs have been assessed by assuming an average cost per inhabitant. The value is obtained through a parametric estimation. The costs obtained, have been transformed into a nine point parametric scale to be input in the model. We highlight that assessing incentive costs seems very difficult at this definition level of the scenarios; however, for the purpose of our analysis we assume that the less attractive scenarios also imply higher costs of this nature. Actually, the scenarios that imply a plausible tourist economic development present major opportunity for cooperation between public and private sectors. Moreover, these plans can improve local activity, and contribute to the conservation of local culture and tradition.

When we look at the environmental criteria it is noteworthy that the scenarios which foresee a spread of the population over 29 municipalities tend to stronger respect territorial relationships even if they imply a drastic land use change, with the likely consequence of urban sprawl.

Finally, from a social standpoint we observe that the scenarios where the population will be concentrated in three poles facilitate the preservation of local identity of the Vesuvio community, but may also present new problems of integration with the current social structure. Moreover, the dispersion scenarios facilitate a gradual relocation over the time.

CHOICE CRITERIA		VESUVIO SCENARIOS			
		1a	1b	2a	2b
Economic	Infrastructure costs	55/75 5	75/90 7/8	45/55 3/4	65/85 7
	Financial incentive costs	high	very high	moderate	high
	Cooperation between public and private sectors	moderate	good	moderate	very good
	Creation of new work opportunities	moderate	good	more or less good	very good
	Creation of new local activities	moderate	very good	moderate	good
Environmental	Observance of territorial relationships	very good	very good	more or less good	more or less good
	Conservation and valorization of cultural heritage	bad	very good	bad	good
	Improvement of urban quality	more or less good	good	very good	very good
	Diversification of relocation	bad	bad	good	good
	Compatibility with existing infrastructure	more or less good	more or less good	good	good
Social	Conservation of local identity	good	very good	very good	good
	Integration with local community	good	good	more or less good	more or less good
	Attractiveness for new residents	bad	moderate	more or less good	very good

Table 6 Impact matrix for the Vesuvio scenarios

## 8.2 The NIADE fuzzy set method

The so-called NIADE method has been applied using a specific software (NIADE 2.0) for fuzzy multicriteria analysis. In Table 7 we report the results obtained by showing a ranking of the scenarios. In particular, the final ranking of the policy scenarios comes from the intersection of two separate rankings: the first one,  $\Phi^+$ , is based on strong and very strong preference relations, where an index value ranging from 0 to 1 indicates how much one alternative is better than all others (the higher the better). The second one,  $\Phi^-$ , is based on weak and very weak preference relations; its index value ranging from 0 to 1 indicates how much one alternative is worse than all others (the lower the better).

In Table 7 the final results show that the policy scenarios where we assumed a concentration of the population in three poles are preferable. In particular the policy scenarios that imply a strong tourist and economic development of the Vesuvio area seem to better meet the goals of the Vesuvio project.

$\Phi_+$		$\Phi_-$		Intersection	Final ranking of policy Scenarios	
0,36	2b ↓	0,05	2b ↓	2b ↓	I	2a
0,22	2a ↓	0,16	2a ↓	2a ↓	II	2b
0,16	1b ↓	0,18	1b ↓	1b ↓	III	1b
0,04	1a	0,39	1a	1a	IV	1a

Table 7 Ranking of Vesuvio scenarios

In the next table we will show the consensus of each stakeholder on the above-mentioned policy scenarios (see Table 8). To stimulate a possible coalition among the stakeholders involved, on the basis of the scenarios, a Forum Group was organized. In this stage the elaborated scenarios were presented to representatives of the stakeholders; each of them expressed a judgment based on his own preference on the realization of one scenario compared to another one. On the basis of the information collected, we were able to construct a social consensus matrix (Table 8). All judgments have been expressed on the basis of the 9-point semantic scale of the NIADE method.

Scenarios \ Stakeholders	1a	1b	2a	2b
National Park of Vesuvio	moderate	very good	more or less poor	more or less good
Province of Naples	more or less poor	good	moderate	very good
Environmental Associations	extremely poor	poor	very poor	extremely good
Entrepreneurs' Associations	more or less good	poor	very good	more or less good

Table 8 Social consensus (equity) matrix

In Figure 8 a dendrogram of a possible coalition of the stakeholders interviewed is offered. This dendrogram is carried out with the aim to explore the consensus reached on the scenarios proposed, and to understand the performance of each alternative in respect to goals set and issues posed. This approach seems to be very useful in this context, since is not only focused on the choice problem, but it also looks at the possibility to construct a new compromise scenario that matches the best performances of all other scenarios. In particular, the results obtained show that for a value of  $\alpha$  (the index of similarity) equal to 0.708, only the interest groups of the Vesuvio National Park and Province of Naples seem to be in agreement on the scenarios proposed, while the Environmental Association and the Industrialists Association can match already a lower value of  $\alpha$  equal to 0.566. The entire group of stakeholders will agree on the scenarios for a similarity value of  $\alpha$  equal to 0.553

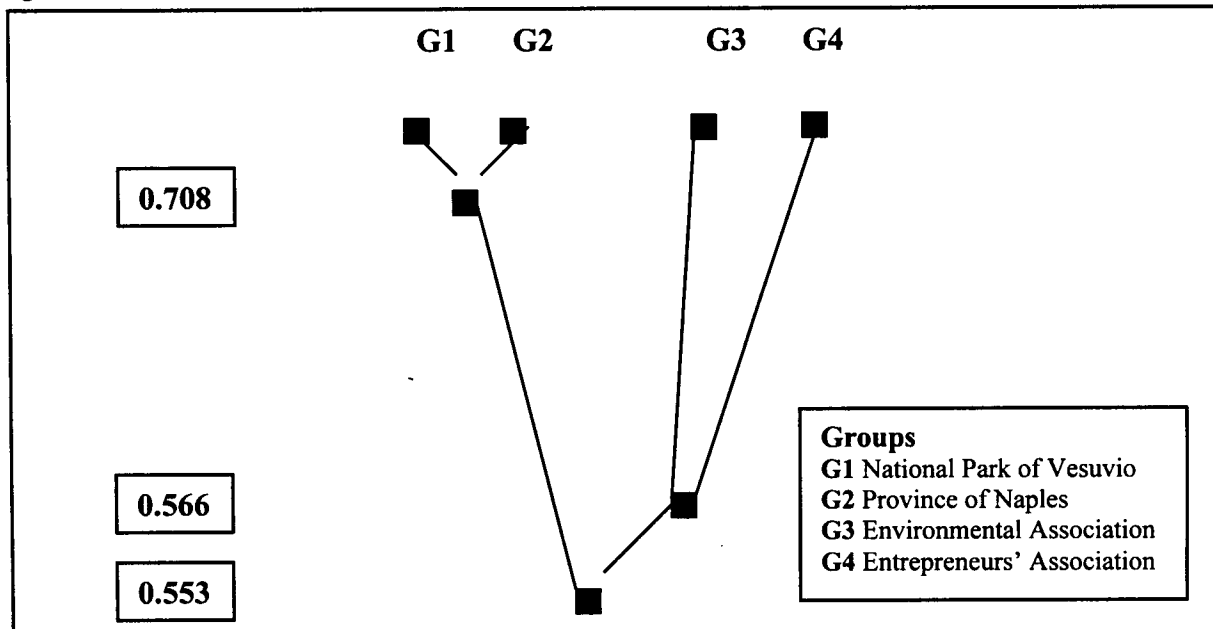

Figure 8 Dendrogram of coalition formation

### 8.3 Result of Regime analysis

The regime analysis is a qualitative-quantitative multicriteria approach that allows to construct a rank order of alternatives. It is then necessary to include the score assessments of the impact matrix as ordinal measurement. In this case an ordinal scale (1,2,3,...) has been used, where the highest value represents the scenario that best fits the relevant criterion (see Table 9).

CRITERIA		SCENARIOS			
		1a	1b	2a	2b
Economic	Infrastructure costs	3	1	4	2
	Financial incentive costs	3	2	4	3
	Cooperation between public and private sectors	2	3	2	4
	Creation of new work opportunities	1	3	2	4
	Creation of new local activities	2	4	2	3
Envi	Observance of territorial relationships	4	4	3	3
	Conservation and valorization of cultural heritage	2	4	2	3
	Improvement of urban quality	2	3	4	4
	Diversification of relocation supply	3	3	4	4

	Compatibility with existing infrastructures	3	3	4	4
Social	Conservation of local identity	3	4	4	3
	Integration with local community	4	4	3	3
	Attractiveness for new residents	1	2	3	4

**Table 9** Impact matrix for Vesuvio policy scenarios

Starting from the impact matrix of Table 9, a rank order of alternatives is carried out with the help of a newly developed software programme for multicriteria evaluation (SAMI programme). Unlike the NAIADÉ method, in the Regime analysis the conflict analysis is carried out by considering the preferences of each stakeholder on the list of criteria defined. In other words, we can define through interviews among stakeholders a weight vector related to each of the relevant criteria. We assume that each actor involved may point out which of the

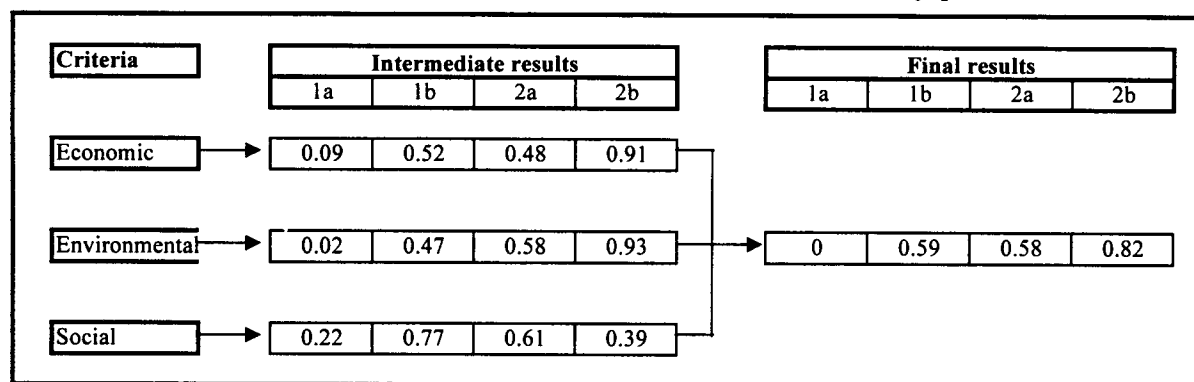

criteria used to assess the impact of the scenario is the most important to reach a pre-defined goal from his standpoint. Without loss of generality we assume here that all criteria have the same importance in the evaluation of scenarios performance. In Table 10 we present the results of Regime analysis.

**Table 10** Results of Regime analysis

The results in the last table show that the policy scenario aiming at a concentration of the Vesuvio community in three territorial poles is preferable. Moreover, the idea to improve the tourist sector, even in the case of a dispersion of people, is winning in respect of the idea to maintain the current economic structure.

## 9 Sensitivity analysis and conclusion

In this last section we will combine the results from the NAIADÉ method and the Regime method to reach a final conclusion. In Table 11 we present a comparison of the results obtained using the two different multicriteria methods as described in the previous sections. Looking at these results we note that they are very consistent; in fact in both cases the scenarios aimed to concentrate the population in three territorial poles seem to be better than the others. This result is also consistent with the aim expressed by the Environmental and Entrepreneurs' Associations to reduce the use of space, and to preserve local features and traditions. Moreover, looking at the economic structure, the scenarios that assumed a strong improvement of the tourist sector are considered to be preferable, especially from the viewpoint of the Environmental Association and the National Park of the Vesuvio. The scenarios 2a and 1b are considered more or less equal in both cases.

RANK ORDER OF SCENARIOS				
	I	II	III	IV
NAIADE	2b	2a/1b	1b/2a	1a
Regime	2b	1b/2a	2a/1b	1a

**Table 11** Survey table of a comparison of multicriteria methods

In conclusion, we may argue that a scientific support for the strategic planning of a vast area like the case of the metropolitan area of Naples, future-visioning methods can offer to decision-makers a useful general and operational framework to map out promising new options. The purpose is not to give them a closed solution to a necessary action, but to help all actors involved in the strategic process to think in a creative way, checking all relevant implications of the proposed choice options.

In the specific case of the Vesuvio area the proposed policy scenarios do not yet represent ready-made real-word implementations of action, but only strategic planning options for the design of possible actions. In this perspective, the descriptive approach of the evaluation methodology appears to be a very useful tool to explore the solution space and to identify relevant driving forces in addressing future options.

The combination of two approaches (scenario analysis and evaluation methodology) appears to offer a new scientific framework to help decision-makers and experts in complex decision making processes and long-term thinking.

### References

- Beinat E., Nijkamp P., (1997), "*Multicriteria Evaluation in Land Use Management*", Kluwer Academic Publisher, Dordrecht, The Netherlands.
- Boulle' P., Vrolijk L., Palm E., (1997), "*Vulnerability Reduction for Sustainable Urban Development*" in *Journal of Contingency and Crisis Management*, Volume 5, Number 3, p.179-188. Blackwell Publishers
- Christensen, K., (1985), "*Coping with uncertainty in Planning*", *Journal of the American Planning Association*, 52, 63-73.
- Comfort L. K., Sungu Y., Johnson D., Dunn M., (2001), "*Complex Systems in Crisis: Anticipation and Resilience in Dynamic Environments*" in *Journal of Contingency and Crisis Management*, Volume 9, Number 3 p.144-158 Blackwell Publishers
- De Luca M., Rallo B. (1998), "*Mobilità delle residenze mobilità delle persone, l'area napoletana*", Studi sul Mezzogiorno, Collana di Studi economico-sociali sul Mezzogiorno.
- Dewulf, G.P.R.M., (1991), "*Limits to forecasting. Toward a theory of forecasting errors*", P.H.D Thesis, State University of Utrecht, Utrecht
- Eduljee, G.H.(2000), "*Trends in Risk assessment and Risk Management*", *The science of total Environment*, 249, 13-23
- Godet M., (1987) "*Scenarios and strategic management*", Butterworths Scientific Ltd, London
- Giaoutzi, M., Nijkamp P., (1993), "*Decision Support Model for Regional Sustainable Development*", Avebury, Aldershot, UK.
- Hirshhorn, L., (1980), "*Scenario writing: a developmental approach*", *Journal of the American Planning Association*, 46, 172-183.

- Jacobs B. (1997), "*Urban Crisis: Complexity and Risk-An editorial Statement*", in Journal of Contingency and Crisis Management, Volume 5, Number 3, p.127-130, Blackwell Publishers
- Joint Research center (1996), ISPRASITE, *NAIADE: manual and tutorial*
- Jungk, R. e Mullert, N., (1987), *Future Workshops: how to create desirable futures*, Institute for Social Inventions, London.
- Kahn H., Wiener A.J., (1967) "*The year 2000*", Mc Millan New York
- Khakee, A., (1999), "*Participatory Scenarios for sustainable development*", Foresight, 1, 229-240.
- Khakee, A., (1991), "*Scenario construction for urban planning*", OMEGA, 19, 459-469.
- May, G. H., (1996), "*The future is ours: foreseeing, managing and creating the future*", Adamantine Press, London
- Makridakis S., Wheelwright S. Mcgee V. E., (1983) "*Forecasting: Methods and application, second edition*" John Wiley & Son, New York
- Munda G (1995), "*Multicriteria Evaluation in a fuzzy environment: theory and application in Ecological Economics*", Phisica – Verlag, Heidelberg
- Nijkamp P. (1994) "*Global Environmental Change: Management Under long-range Uncertainty*" in The International Library of Management -Risk Management- Volume II Management And Control. Ashgate, USA
- Nijkamp P., Rietveld P., Voogd H. (1990), "*Multicriteria Evaluation for Physical Planning*", Elsevier Science, Amsterdam, The Netherlands.
- Nijkamp P., Rienstra S., and Vleugel J. (1998) "*Transportation planning and the future*", John Wiley, New York
- Nijkamp P. Torrieri F. Vreeker R. (1999) "*A Decision Support System for assessing alternative projects for the design of a new road network- Methodology and application of a case study-*" Serie Research Memoranda, Free University, Amsterdam The Netherlands
- Provincia di Napoli, Città Metropolitana, Assessorato al Piano Territoriale di Coordinamento e Progetti speciali (1999) "*Piano Territoriale di Coordinamento*" Progetto Preliminare.
- Schoemaker, P. J. H., (1995), "*Scenario planning: a tool for strategic thinking*", Sloan Management Review, Winter, 25-40.
- Stern E. (1997), "*Crisis and Learning: A conceptual Balance Sheet*", in Journal of Contingency and Crisis Management, Volume 5, Number 2, p.69-86. Blackwell Publisher
- Ravetz, J., (1999), "*What is Post-normal science*", *Futures*, 31, 467-453.
- Van Geenhuizen M. Nijkamp.P., (1995) "*Sustainable cities: challenges of an integrated planning approach*" Serie Research Memoranda, Free University, Amsterdam, The Netherlands
- Van Geenhuizen M., Thissen W., (2001) "*Uncertainty and Intelligent Transport system: Implication for policy*", International Journal of Technology, Policy and Management Vol. 1, N°3
- Vleugel J. (2000) "*Design of transport and land use scenarios –Principles and application-*" P.H.D Thesis, Free University of Amsterdam, Amsterdam.
- Ulrich B., (1999), "*World risk society*", Polity Press, Cambridge, UK
- Zeleny M., (1994) "*In search of cognitive equilibrium: Beauty, Quality and Harmony*" Journal of Multicriteria Decision analysis, Vol. 3, 3-14